

21st Nordic Seminar on Railway Technology

Tampere University / Tornio Hotel Tampere

Tampere, FINLAND

21 – 22 June 2022

Abstracts



Table of contents

Session	Authors	Title	Page
1.1	Stahl	<i>Recent developments of mass-spring-systems</i>	4
1.1	Ekberg, Kabo	<i>Estimating risks of track buckling</i>	5
1.1	Sresakoolchai et al	<i>Railway turnout support deterioration estimation under flooding condition using machine learning</i>	6
1.1	Varis, Rantala, Luomala	<i>The effect of convex bearers on track geometry errors</i>	7
1.2	Singh, Rantatalo	<i>AI driven Decision support system for different levels of Railway Automation</i>	8
1.2	Djordjevic, Fröidh	<i>Introduction of ATO in Rail Freight: Attitudes and Views</i>	9
1.2	Kulkarni et al	<i>iVRIDA: Intelligent Vehicle Running Instability Detection Algorithm for high-speed rail vehicles using sensor fusion and deep learning methods – A pilot study</i>	10
1.2	Kordnejad et al	<i>Demonstration and Evaluation of the Intelligent Video Gate Concept</i>	11
1.3	Salmenperä et al	<i>Online track condition monitoring based on bogie vibration data</i>	13
1.3	Pieringer, Kropp	<i>A time-domain method to estimate rail roughness from axle box acceleration</i>	14
1.3	Jönsson	<i>System for IOT Measurements of Ride Comfort</i>	15
1.3	Silvast	<i>Multi-Source Railway Condition Data Analysis for Optimized Track Maintenance Planning</i>	16
1.4	Kumari et al	<i>Bayesian Statistics for Fleet Management of Rolling Stock</i>	17
1.4	Compierchio, Tretten	<i>A Backpropagation Algorithm for use of Renewable Energy Along Railway Lines</i>	18
1.4	Eriksson et al	<i>Statistical analysis of curve squeal based on long-term onboard noise measurements</i>	19
1.4	Derosa et al	<i>Overhead contact wire wear: a heuristic model for Norwegian conditions</i>	20
2.1	Pelho et al	<i>Modelling the railway induced ground vibrations in soft soil areas of Western Finland</i>	21
2.1	de Man	<i>Vibration insulation solutions for track structures: the important role of insertion loss for specifications</i>	22
2.1	Theyssen et al	<i>Noise and vibration mitigation on low-vibration track</i>	23

2.1	Aggestam, Nielsen	<i>Comparison of the dynamic response between traditional and innovative railway track systems</i>	24
2.1	Luomala et al	<i>Evaluation methods and in-situ measurements of Ground Vibration Boom</i>	25
2.2	Leung et al	<i>Predicting RCF Crack Initiation in Rails using Critical Plane Fatigue Damage Parameters</i>	26
2.2	Rajamäki	<i>Statistical analysis of railway rail wear measurements</i>	27
2.2	Ansin et al	<i>Simulation and field tests of long term rail profile damage in a curve due to plasticity, wear and surface crack initiation</i>	28
2.2	Talebi et al	<i>Crack initiation criteria for deformed anisotropic R260 rail steel</i>	29
2.2	Prettner	<i>Track Experiences with 400GHT® Grooved Rails</i>	30
2.3	de Leeuw et al	<i>Prediction of Wheel-Wear for a Metro Vehicle</i>	31
2.3	Lundgren	<i>Service life of wheels on regional trains</i>	32
2.3	Maglio et al	<i>Influence of wheel and rail deterioration on wheelset fatigue life</i>	33
2.3	Nielsen et al	<i>Probability of rail break due to wheel–rail impact loads</i>	34
2.3	Sormunen et al	<i>Using wheel measurements in lifecycle management</i>	35
2.4	Asplund et al	<i>Rail surface treatment - grinding vs milling in terms of equivalent conicity</i>	36
2.4	Ait-Ali et al	<i>Evaluation of long-term maintenance of switches & crossings with respect to life-cycle costs and socio-economic impact</i>	37
2.4	Offenbacher	<i>Ballast condition assessment via tamping machine measurements</i>	38
2.4	Aronen, Seppälä	<i>Instructions on Design and Implementation of Tamping on Finnish State Rail Network</i>	39
2.4	Marschnig et al	<i>Long Term Effects of Reduced Track Tamping Works</i>	40
3.1	Nasrollahi et al	<i>Prediction of differential track settlement in transition zones using a non-linear track model</i>	41
3.1	Tolla, Andersson-Berlin	<i>Train load effect on a buried structure</i>	42
3.1	Peltomäki et al	<i>Modeling the loading behavior of railway structure</i>	43
3.2	Landström et al	<i>Improved modelling of tread braked wheels using an advanced material model and brake rig test</i>	44
3.2	Vernersson, Lundén	<i>Tread braking and winter conditions</i>	45

3.2	Lundén, Vernersson, Walia	<i>Wear of wheel treads and brake blocks at railway tread braking</i>	46
3.3	Persson, Jönsson	<i>Predicting equivalent conicity by Gradient Index Profile</i>	47
3.3	Khoramzad et al	<i>Estimation of traction at high creepages and its application to prediction of wear, RCF and squeal noise</i>	48
3.3	Shaik	<i>Track-friendliness of freight wagons on the Finnish Rail Network</i>	49
3.4	Latvala, Luomala	<i>The effect of water content on permanent deformations in railway structure</i>	50
3.4	Jiang, Rønnquist, Frøseth	<i>Application of a Robust Photogrammetry Method for Uplift Measurements of Railway Catenary Systems in Noisy Backgrounds</i>	51
3.4	Chen et al	<i>The railway catenary condition monitoring: a systematic mapping</i>	52
4.1	Sauni et al	<i>Visualising track geometry deterioration modelling</i>	53
4.1	Berggren et al	<i>Track geometry quality measurements from working machines</i>	54
4.1	Li	<i>A study on the use of Short-Time Fourier Transform (STFT) analysis for track geometry evaluations concerning cyclic irregularities</i>	55
4.1	Loidolt	<i>Evaluating turnouts using post-positioned measuring car data inclusive the rail surface signal</i>	56
4.2	Carlvik, Lau, Frøseth	<i>Systematic Mapping Review on Railway Track Condition Monitoring 2016-2021</i>	57
4.2	Kour, Patwardhan, Karim	<i>Cyber Resilient approach for Railways</i>	59
4.2	Patwardhan, Thaduri, Karim	<i>Railway catenary digital twin: structure, representation and analytics</i>	60
4.2	Sunnari, Kaaranen	<i>Railway Digitalization – Finnish Frontier</i>	61
4.3	Casanueva et al	<i>Universal Cost Model: railway system interdependencies in LCC analyses</i>	62
4.3	Ivina, Palmqvist	<i>Use of reserved capacity for basic maintenance in Sweden</i>	63
4.3	Got, Lane, Klasila	<i>Digitalizing supervision activities and documentation</i>	64
4.3	Liu, Berg, Bustad	<i>Developing An Energy Labelling System for Rail Vehicles: A Survey of European Railway Stakeholders</i>	65

Recent developments of mass-spring-systems

Walter Stahl¹

¹ Chair and Institute of Road, Railway and Airfield Construction, Technical University of Munich, Munich, Germany.
walter.stahl@tum.de

Introduction

Mass-Spring-systems or floating slabs are generally the most effective measure to reduce ground borne vibrations or ground borne noise in buildings adjacent to tracks. However, they are technically most complicated and therefore an expensive method. There are different point of views about design and layout of these oscillatory systems regarding the vibration mitigation and the structural design. A brief description of artificial tests on resilient elements is given

State of the Art and recent developments

Mass-Spring-Systems have been built e.g. in Germany and Austria as slab tracks and ballasted tracks with sleeper panels. Proven design rules are existing regarding the mass and the total height of the installation. “Trends” in design are divided planning, minimized cross sections and a detailed definition of the natural frequency after the determination of the transfer function of the finished tunnel. This may lead to constricted cross sections connected with constricted mass, increased bending of the slabs and increased resiliency and strain of the bearing elements.

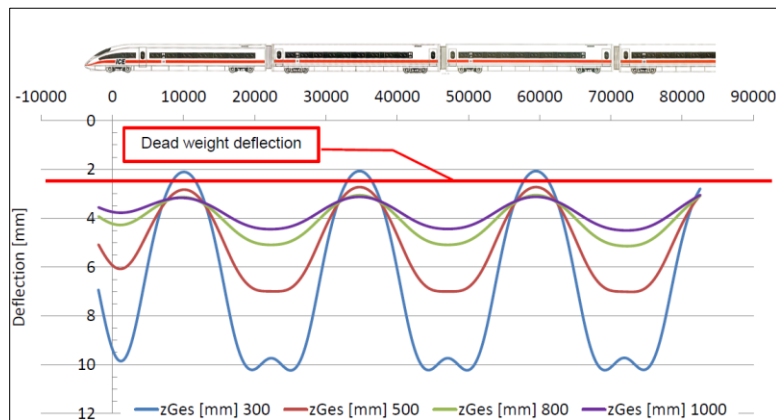

Figure 1. Bending of slabs with different thickness @ 10Hz System.

The design should be separated in a structural design (track safety) and the design in protection against vibration using different load and calculation models. The DIN-Standard 45673-7 suggests different design and test loads depending on the individual lay out of the Mass-Spring-Systems. A European Standard, which is in preparation, follows this point of view.

Conclusion

A consideration of vibration protection measures even at the beginning of the implementation planning will lead to sustainable systems and an environmental protection.

Estimating risks of track buckling

Anders Ekberg and Elena Kabo

CHARMEC, Chalmers University of Technology, Gothenburg, Sweden. anders.ekberg@chalmers.se
elena.kabo@chalmers.se

Introduction

Track buckling is a safety related form of failure that is inherently difficult to analyse and predict. This instability phenomenon occurs when the loading caused by restricted thermal expansion (in addition to longitudinal and lateral wheel–rail forces) exceeds the lateral resistance of the track, see Figure 10a. Since it is a local phenomenon, a major challenge is to identify the metres where track buckling is most likely among the thousands of kilometres of track in a network. The current presentation will highlight an approach to this that combines numerical simulations and analysis of track buckling data.

Numerical analysis

Although inherently an instability issue, the non-ideal track geometry, and the track resistance will cause a more gradual increase in deformation as temperature increases. Thus, there is no possibility to identify a critical temperature. The approach taken was instead to identify an equivalent temperature increase, $\Delta T_{2.5}$. It represents the difference in temperature to cause a 2.5 mm lateral displacement between a reference configuration, and a studied configuration, see Figure 10b. In this manner, effects of curves, hanging sleepers *etc* can be quantified. Examples of results are presented at the seminar.

Data analysis

Numerical analyses are efficient in quantifying effects of well-defined parameters, but not well-suited to capture the effect of more “fuzzy” parameters such as “track works”, and vicinity to “fixed points” (e.g., switches & crossings). To this end, data analysis of Trafikverket’s track buckling reports 2008–2019 was employed. The analysis assumed that the adjusted temperature at track buckling should follow a normal distribution. This allowed estimations of the influence of the “fuzzy” parameters. As an example, “fixed points” were found to have a minor influence. Further results are presented at the seminar.

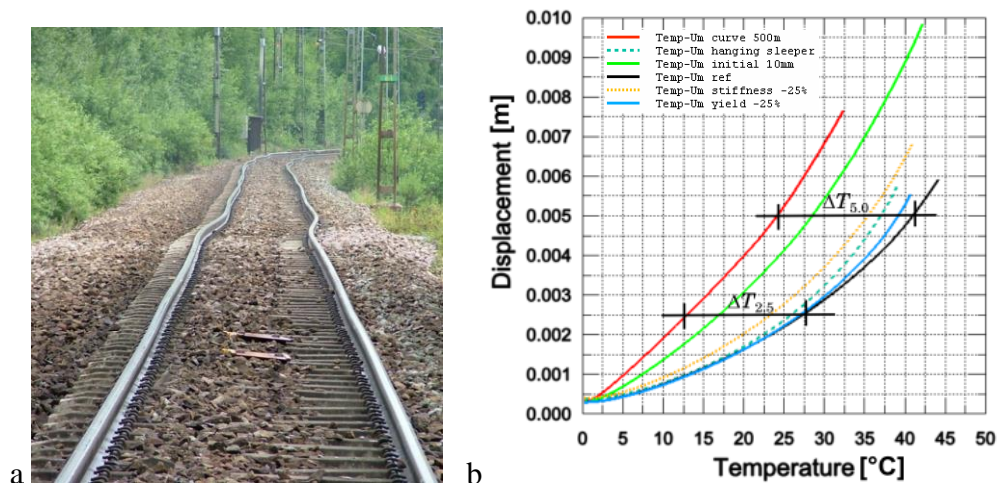

Figure 1. a) Track buckling. b) Equivalent temperature increase (reference case in black).

Railway turnout support deterioration estimation under flooding condition using machine learning

Jessada Sresakoolchai¹, Sakdirat Kaewunruen² and Mehmet Hamarat³

¹ Department of Civil Engineering, University of Birmingham, Birmingham, United Kingdom, B15 2TT.
jss814@student.bham.ac.uk

² Department of Civil Engineering, University of Birmingham, Birmingham, United Kingdom, B15 2TT.
s.kaewunruen@bham.ac.uk

³ Department of Civil Engineering, University of Birmingham, Birmingham, United Kingdom, B15 2TT.
mzh670@student.bham.ac.uk

Abstract

Railway turnout is a critical component of the railway system. At the same time, it is a weak point in the railway structure because it is movable and contains connections. In the case of the ballast structure, railway turnouts are supported by crushed rocks which continuously deteriorate. However, the support may deteriorate rapidly in some situations such as flooding. Flooding can severely deteriorate the stability of the railway structure. Railway operations are critically affected by this deterioration because the maintenance will disturb regular operations. An ability to estimate the deterioration of the railway turnout support will enhance the efficiency of the maintenance plan. This study aims to develop a machine learning model to estimate the railway turnout support deterioration. The estimation is conducted based on deterioration severity classification. The machine learning technique used to develop the model is a convolutional neural network. A key parameter used to estimate the railway turnout support deterioration is axle box acceleration. Validated numerical models are used to simulate the railway turnout behavior under flooding conditions. The numerical models are developed using the finite element method. An expected contribution of this study is the developed machine learning model can be used to estimate the deterioration of railway turnout support which will be beneficial to railway maintenance.

The effect of convex bearers on track geometry errors

Riku Varis¹, Tommi Rantala² and Heikki Luomala³

¹ Faculty of Built Environment, Tampere University, Tampere, Finland. riku.varis@tuni.fi

² Faculty of Built Environment, Tampere University, Tampere, Finland. tommi.rantala@tuni.fi

³ Faculty of Built Environment, Tampere University, Tampere, Finland. heikki.luomala@tuni.fi

Introduction

Generally, concrete bearers are assumed to be completely straight. In reality, the situation is not like that. Because of the prestressed structure, bearer tends to bend in horizontal direction. This is not severe problem in short bearers, but with long bearers the convexity of structure can have a significant effect on the geometry of turnout.

Analysis

In this research, convexity of bearers has been evaluated in almost 30 turnouts. The curved shape of unloaded bearers have been evaluated with tachometer in four points measured next to each rail. Also track geometry measurement trolley was used to continuously measure the vertical position of the whole turnout area and evaluate curvature of bearers through that.

Typically, convexity is only 2-4 millimeters, but it can change with loading. The biggest problem is the crossing area, where long-term dynamic stress can gradually cause straightening of those convex bearers and that way local level errors. The tamping machine can try to bend concrete bearers back to their original shape, but because of the stiffness of concrete, this has no permanent effect. In these situations, adjustment plate between rail and bearer are often needed.

Another major problem area is the heel of turnout, where long bearers change to two separate short bearers. Typically, straight route attends to settle more than diverging route. Short bearers are normally settling evenly in vertical direction, but long bearers starts to settle unevenly creating cant towards straight route. In this situation cant and especially twist errors develops in that transform area.

Conclusions

For conclusion, with convex bearers it is impossible to reach completely horizontal track geometry both in straight and diverging route at the same time. Because of that, the convex shape of bearers should be taken into account when tamping. Those bearers should not be forced to be straight, because this kind of forcing will normally lead to either changing the geometry of straight track or cracking the bearers. For that reason, the cant in the diverging route should be leaved there, because that is acceptable in diverging route due to much slower speed on that track.

The results in this study also concluded that in most cases you cannot remove the rail adjustment plates during the next tamping procedure without replacing also bearers and sometimes even steel parts at the same time.

AI driven Decision support system for different levels of Railway Automation

Sarbjee Singh¹ and Matti Rantatalo¹

¹Division of operation and Maintenance Engineering, Luleå University of Technology, Sweden. Sarbjeeet.singh@ltu.se
Matti.rantatalo@ltu.se

Abstract

Decision-making for operation and maintenance in future railway systems, which might include a higher degree of autonomy, will face numerous challenges. These challenges can be appropriate identification of obstacle on the track, timely instruction to wayside maintenance team, safe level crossings, effective Fatigue Risk Management System (FRMS), active Public information Interface etc.

Future railway system will be a complex, Human Cyber Physical System (R-HCPS). The data from physical system to cyber system undergoes AI based machine cognition & analysis, which exchanges this information with human intelligence. The human intelligence and machine intelligence can further assist in developing a collaborative knowledge base using system intelligence, artificial intelligence (AI) and interactive information in R-HCPS (Figure 1) for successful decision-making.

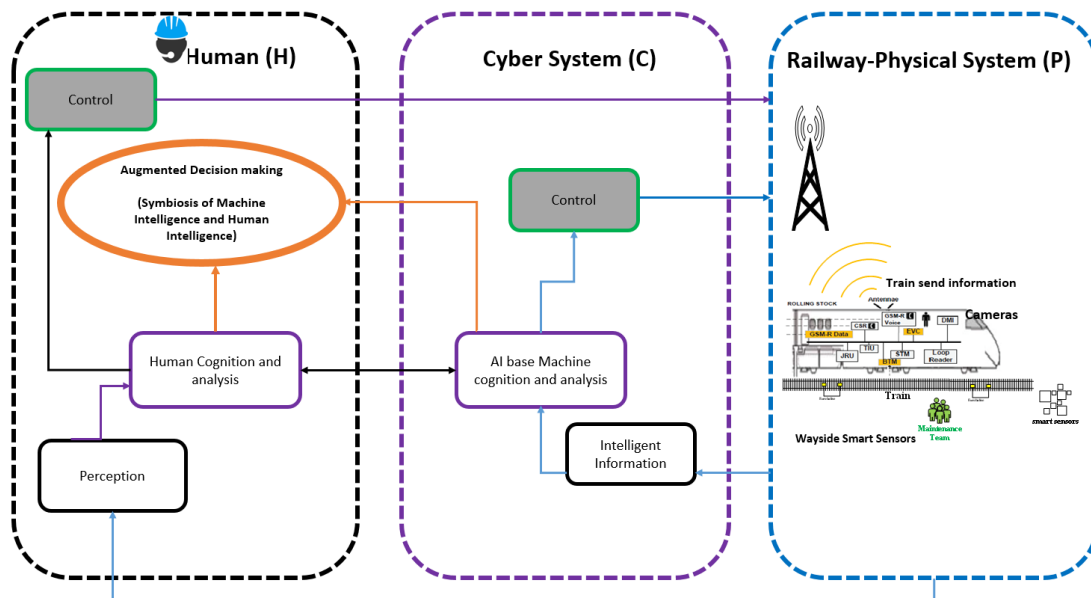

Figure 1. Railway-Human Cyber Physical System (R-HCPS) (modified from Zhou et al., 2018)

References

Zhou, Ji., Li, P., Zhou, Y., Wang, B., Zang, J., Meng, L., "Toward New-Generation Intelligent Manufacturing", *Engineering*, 4 (1), pp. 11-20, 2018

Introduction of ATO in Rail Freight: Attitudes and Views

Boban Djordjevic^{1*}, Oskar Fröidh¹

¹ KTH Royal Institute of Technology, Stockholm, Sweden

boband@kth.se, oskar.froidh@abe.kth.se

* Corresponding author

Introduction

The use of ATO (Autonomous Train Operation) in rail freight is mentioned and suggested as one of the possible technologies to achieve the target of 30% modal share by 2030 (CER & RFF, 2020), (Emery, 2017).

The objective of this study is to identify and classify the challenges, risks and positive impacts of the use of ATO in rail freight based on the first round of the Delphi survey.

Analysis

The results of the first round of the Delphi method are presented. All results of the first round of Delphi were summarised into strengths, weaknesses, opportunities and threats related to the introduction of ATO in rail freight. The first round of Delphi panel includes 27 experts from the ATO field. The experts are searched in academic databases through the relevant publications and LinkedIn network based on their experience with ATO and railway signaling systems.

Proactive communication network, train location and obstacle detection, appropriate use of braking systems, integration with signaling systems, automation of shunting operations, a mixed traffic environment, train dynamics, and challenges related to objectives such as capacity increase, energy efficiency and punctuality have been pointed out as a challenges. With the move to a higher grade of automation (GoA), there is an opportunity to address additional challenges. The initial phase of ATO, matching brakes to train composition, automation reliability, operating environment, and retrofitting locomotives with ATO are the major risks highlighted by participants. The main benefit of ATO in rail freight is to improve rail performance such as punctuality, safety, punctuality, capacity and energy efficiency. Most benefits would increase at higher GoAs, but some participants believe that there is no difference between GoA3 and GoA4. Regarding the threats participants pointed out mixed use of ATO, insufficient testing of the solutions, costs to retrofit of rolling stock with ATO, unforeseen situations during operation, reliability of automated systems, unattended coupling and decoupling of vehicles and cyberattacks.

Conclusions

The introduction of ATO in rail freight is highly dependent on the acceptance and commitment of operators, authorities, politicians and public opinion, as well as on the alignment of the regulatory framework between operators and infrastructure managers. The results of the study are primarily useful for railway undertakings (RUs), infrastructure managers (IMs) and policy makers. Based on the results, the time and cost of decision making for ATO implementation can be reduced.

References

1. CER and RFF (2020). 30 by 2030 – how rail freight achieves its goals.
2. Emery, D. (2017). Towards Automatic Train Operation for long distance services: State-of-the art and challenges. *17th Swiss Transport Research Conference*.

iVRIDA: Intelligent Vehicle Running Instability Detection Algorithm for high-speed rail vehicles using sensor fusion and deep learning methods – A pilot study

Rohan R Kulkarni¹, Rocco Libero Giossi, Prapanpong Damsongsaeng, Alireza Qazizadeh and Mats Berg

¹ Department of Engineering Mechanics, KTH Royal Institute of Technology, SE100 44, Stockholm, Sweden.
rohank@kth.se

Abstract

Vehicle running instability is an important phenomenon in vehicle-track dynamic interaction and typically appears at a fairly high vehicle speed on a straight track or in large-radius curves (Kulkarni et al., 2020). The running instability is an intrinsic system behaviour that is dependent on the health of the vehicle and track subsystems. The foremost causes of running instability are poor vehicle yaw dampers, too soft primary suspension in the horizontal plane or poor wheel-rail interface (Kulkarni, Qazizadeh, Berg, Carlsson, & Stichel, 2021). Vehicle running instability is a safety concern and can also cause passenger discomfort. The *EN 14363:2016+A1 - Railway applications – Testing and simulation for the acceptance of running characteristics of railway vehicles – Running behaviour and stationary tests*, (2019) specifies the methods to determine vehicle running instability in the vehicle certification phase. However, these methods are not suitable for continuous health monitoring of the vehicle and track subsystems. The proposed schematic of a data-driven Fault Detection and Isolation (FDI) method is shown in Figure 1 (Kulkarni, Qazizadeh, Berg, & Stichel, 2019).

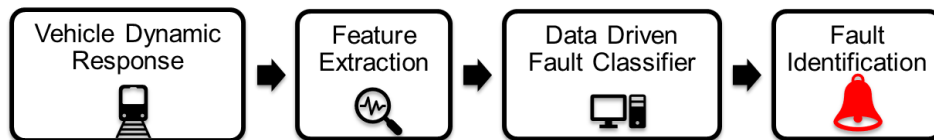

Figure 1 Schematic of FDI method

The data-driven FDI algorithm is a four-step process: vehicle dynamics response, signal feature extraction, deploying fault classifier, and fault identification. Signal features used in the configuration of the data-driven fault classifier are the most influencing factors for the accuracy of the classifier. In (Gasparetto, Alfi, & Bruni, 2013) the authors employ Random Decrement Technique (Random Decrement Technique) to extract the vehicle's instable frequency and residual damping from bogie frame accelerations. These signal-based features are fed into k Nearest Neighbor (kNN) and Artificial Neural Network (ANN) fault classifiers to diagnose the reason behind the observed vehicle running instability, mainly vehicle-based faults. In (Ning, Liu, Ouyang, Chen, & Zhang, 2018), the authors propose data-driven fault classifiers combined with data fusion of multiple bogie frame accelerations for diagnostics of vehicle running instability. The authors employ Empirical Mode Decomposition (EMD) and Sample Entropy (SE) methods to extract features associated with small amplitude running instability and incorporate the Support Vector Machine (SVM) classifier as fault identifier. In (Zeng, Zhang, & Song, 2020) the authors use a phase-space reconstruction algorithm to extract signal-based features to estimate state variables' periodicity in the non-linear dynamic system and detect instability based on axlebox accelerations. The papers above, mainly extract features from axlebox acceleration or bogie frame accelerations; however, these researchers do not focus on intelligent fault identification of vehicle running instability.

In the present paper, the iVRIDA algorithm is proposed based on data of carbody floor accelerations and bogie frame accelerations. The iVRIDA algorithm utilizes two data-driven methods namely Dynamic Mode

Decomposition (DMD) and Convolutional Neural Network (CNN) (Brunton & Kutz, 2019) aiming at detecting the vehicle's running instability and identifying root causes of the same. The vehicle running instability detection algorithm is implemented based on a binary classification method using outputs from DMD of carbody floor accelerations. The DMD method has the capability to estimate the frequency and mode shapes of the carbody and it is shown to be 99% accurate for vehicle instability detection. The vehicle running instability root cause identification is formulated as a multiclass classification problem. In this problem, the features extracted from DMD of carbody floor accelerations and features extracted from 2D images of transfer function (Kulkarni, Qazizadeh, & Berg, 2021) between bogie frame accelerations and track are fused together. In this multiclass classification problem, the Linear Discriminant Analysis (LDA) classifier gives an accuracy rate of 81.8% to detect yaw dampers faults. Thus, the combination of the DMD algorithm and CNN architecture (ResNet50) has the potential to identify the fault of yaw dampers when vehicle running instability occurs.

References

- Brunton, S. L., & Kutz, J. N. (2019). *Data-Driven Science and Engineering*. Cambridge University Press. Cambridge University Press. <https://doi.org/10.1017/9781108380690>
- EN 14363:2016+A1 - Railway applications – Testing and simulation for the acceptance of running characteristics of railway vehicles – Running behaviour and stationary tests. (2019).
- Gasparetto, L., Alfi, S., & Bruni, S. (2013). Data-driven condition-based monitoring of high-speed railway bogies. *International Journal of Rail Transportation*, 1(1), 42–56. <https://doi.org/10.1080/23248378.2013.790137>
- Kulkarni, R., Qazizadeh, A., & Berg, M. (2021). Identification of vehicle response features for onboard diagnosis of vehicle running instability. In *Proceedings of the Second International Conference on Rail Transportation* (pp. 1–8). Chengdu.
- Kulkarni, R., Qazizadeh, A., Berg, M., Carlsson, U., & Stichel, S. (2021). Vehicle running instability detection algorithm (VRIDA): A signal based onboard diagnostic method for detecting hunting instability of rail vehicles. *Proceedings of the Institution of Mechanical Engineers, Part F: Journal of Rail and Rapid Transit*. <https://doi.org/10.1177/09544097211020578>
- Kulkarni, R., Qazizadeh, A., Berg, M., Persson, I., Dirks, B., Jönsson, L.-O., ... Wingren, J. (2020). Investigating the effect of the equivalent conicity function's nonlinearity on the dynamic behaviour of a rail vehicle under typical service conditions.
- Kulkarni, R., Qazizadeh, A., Berg, M., & Stichel, S. (2019). Fault Detection and Isolation Method for Vehicle Running Instability from Vehicle Dynamics Response Using Machine Learning. In *Proceedings of BOGIE'19*. Budapest.
- Ning, J., Liu, Q., Ouyang, H., Chen, C., & Zhang, B. (2018). A multi-sensor fusion framework for detecting small amplitude hunting of high-speed trains. *Journal of Vibration and Control*, 24(17), 3797–3808. <https://doi.org/10.1177/1077546318787945>
- Zeng, Y., Zhang, W., & Song, D. (2020). A new strategy for hunting alarm and stability evaluation for railway vehicles based on nonlinear dynamics analysis. *Proceedings of the Institution of Mechanical Engineers, Part F: Journal of Rail and Rapid Transit*, 234(1), 54–64. <https://doi.org/10.1177/0954409719830177>

Demonstration and Evaluation of the Intelligent Video Gate Concept

Behzad KORDNEJAD¹, Ingrid NORDMARK¹, Martin KJELLIN², Martin ARONSSON², Guillermo RIUS GARCIA³, Santiago CASTRO VILABELLA³, Rico WOHLRATH⁴, Roald LENGU⁵, Mats ÅKERFELDT⁶ and Jan BERGSTRAND⁶

¹Division of Transport Planning, KTH Royal Institute of Technology, Stockholm, Sweden Behzad.kordnejad@kth.se,
²RISE, Stockholm, Sweden, ³Indra, Madrid, Spain, ⁴DB Cargo AG, Mainz, Germany, ⁵Hitachi Rail, Genova, Italy,
⁶Trafikverket, Stockholm, Sweden

Introduction

Novel detection and identification technologies, such as optical character recognition (OCR) and radio-frequency identification (RFID) and their applications within rail based transport chains, enable reduction of manual activities and higher degree of automation and digitalization. To initiate the next logical step to a higher level of automation and to reduce the lead-time needed for the identification/verification process of freight trains, the concept “Intelligent Video Gates” (IVG) has been introduced within the Shift2Rail initiative and the project FR8RAIL III WP3.

Analysis

The methodology is based on implementation and evaluation of full-scale demonstration gates installed in Gothenburg, Sweden and Nürnberg, Germany where the gates capture data through OCR and RFID from rolling stock and intermodal loading units (ILUs). The study emphasizes two aspects of the concept; image processing and data sharing. Regarding image processing, this task uses the application of deep learning and computer vision algorithms, where alternatives are investigated for the deployment of the different artificial intelligence models relevant for the rail sector. Regarding data sharing, a platform has been created in order to share the captured data in a secure manner, both considering the output of the image processing and the recorded RFID tags.

Conclusions

This part of the study entails the final evaluation of the demonstrator and the identified use cases; detection of dangerous goods placards and their connection traffic management systems (TMS), detection of damages on rolling stock and ILUs, data sharing for internal node operations and data sharing for supply chain exchange. The evaluation of these use cases can be regarded as a feasibility study indicating how the shared data can be exploited. A set of evaluation criteria has been defined in order to assess the feasibility of the concept. The final evaluation of the demonstrator will highlight possible paths for future research and development of the concept.

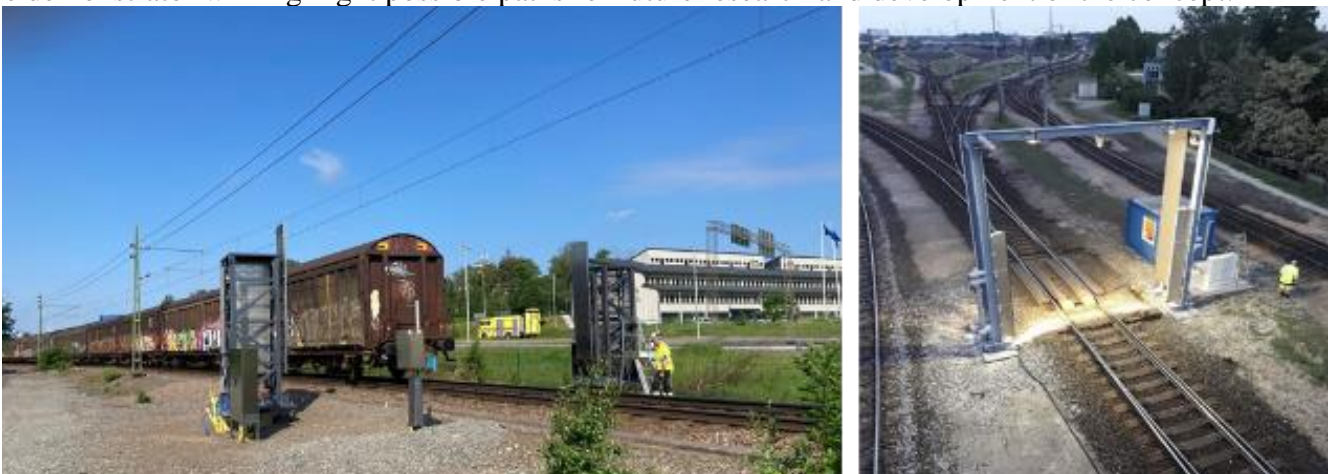

Figure 1. Full-scale demonstration gates in Gothenburg, Sweden (left) and Nürnberg, Germany (right)

Online track condition monitoring based on bogie vibration data

Pekka Salmenperä¹, Marko Lehtosaari² and Antti Laiho³

¹ VR FleetCare, pekka.salmenpera@vr.fi

² Väylävirasto, marko.lehtosaari@vayla.fi

³ EKE Electronics Ltd., antti.laiho@eke.fi

Introduction

In this paper, results from railway track condition monitoring are presented. A railway locomotive bogie instrumented with accelerometers which monitor track condition. The paper focuses on presenting results from online condition monitoring system which detected surface defects on a certain track section in Southern Finland. The results are compared to track inspection car observations of track geometry.

Analysis

Railway bogie axlebox vibration has previously been utilized for track condition monitoring (Sunaga 1995, Molodova 2011). This work investigates long-term vibratory data including yearly variations (summer/winter), combined with synchronous inertial measurement unit (IMU) and positioning data. Time-frequency analyses are utilized to process short-time phenomena in raw data.

Conclusions

The results show that the online track condition monitoring system is highly sensible for track defects. The defects are also visible in corresponding inspection car results but at most as ‘C’ class faults which means early phase fault that should be monitored and possibly repair (RHK 2005). Defects are underestimated because inspection car measures track geometry, not rail defects.

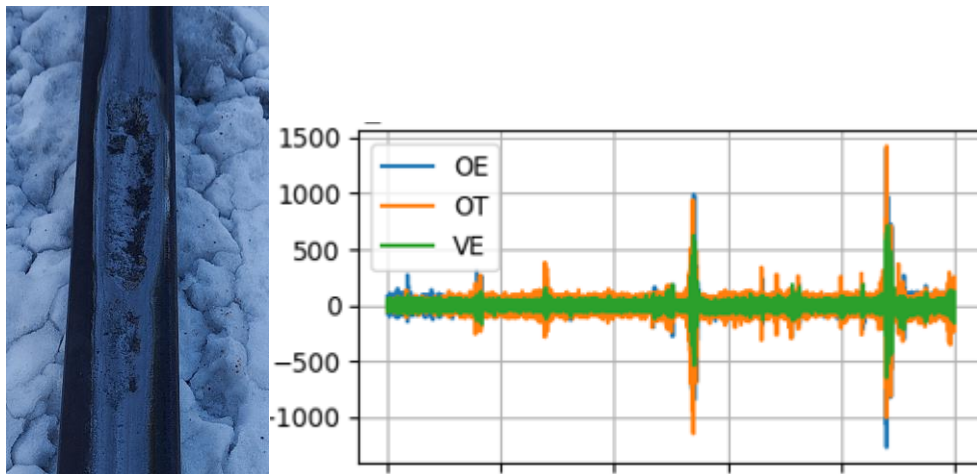

Figure 1. Railway track surface defect, skid pot (left), measured axlebox acceleration (right)

References

- Sunaga, Y, Saro I and Ide T. A practical use of axle-box acceleration to control the short wave irregularities. Report no. 2, 1995. RITI.
- Molodova M, Li Z and Dollevoet R. Axle-box acceleration measurements and simulation for detection of short track defects. Wear 2011; 271: 349-356’.
- RHK. Raiteentarkastustulokset ja niiden tulkinta. 2005
URL: https://julkaisut.vayla.fi/pdf4/rhk_radantarkastusohjeita_raiteentarkastustulokset.pdf

A time-domain method to estimate rail roughness from axle box acceleration

Astrid Pieringer and Wolfgang Kropp

Applied Acoustics/CHARMEC, Chalmers University of Technology, Göteborg, Sweden. astrid.pieringer@chalmers.se

Infrastructure managers require knowledge about the acoustic surface quality of the rails in their network. This allows directing grinding actions to where they are needed to reduce rolling noise and large wheel/rail forces. To be able to measure rail roughness on a large scale, indirect measurements onboard railway vehicles must be carried out since direct measurement procedures with e.g., hand-operated trolleys are slow and laborious and require access to the track that must be closed for train operation. Existing indirect methods use either axle box acceleration (ABA) or under-coach noise measurements to monitor the rail roughness indirectly. The two main challenges with such methods are to separate wheel and rail roughness and to take into account varying track dynamics in the railway network. Both these questions have not yet been addressed sufficiently.

In this work, an enhanced method for estimating rail roughness from railway vehicles has been developed. The method based on the time-domain model WERAN (Pieringer 2014) estimates the time series of the roughness from the time series of ABA. In a first step, the time series of the contact force is calculated from the ABA using a Least Mean Square algorithm (Kropp 2021). In a second step, the combined wheel/rail roughness is obtained from the contact force based on a non-linear Hertzian contact model and a convolutional approach to determine wheel and rail displacement. Separation of wheel and rail roughness is possible by cycle averaging (Németh 2008) of the contact force. The method was tested for simulated data and the influence of uncertain track parameters was assessed. In the relevant wavelength range from 0.5 m to 5 mm, the rail roughness could be estimated with good accuracy for known track dynamics. Overall, deviations in third-octave bands between estimated and actual roughness were below 1 dB. Only for low rail roughness, higher deviations of less than 2.5 dB occurred around the pinned-pinned resonance frequency. Uncertainties in the track parameters affect the roughness estimation, where the most critical parameter is the rail pad stiffness. A deviation of 20% in the rail pad stiffness leads to deviations in the rail roughness of up to 3.5 dB in single third-octave bands. The results illustrate the need to extend the method for the simultaneous extraction of track parameters and roughness from measured ABA.

References

- Pieringer, A., Kropp, W. and Nielsen, J.C.O. “The influence of contact modelling on simulated wheel/rail interaction due to wheel flats.” *Wear*, 314(1-2), pp.273-281, 2014
- Kropp, W., Larsson, K., Lobato, T. and Sottek, R., “Application of the LMS algorithm to identify the surface velocity responsible for the radiated sound pressure”, *Acta Acustica* 5 (32), 2021
- Németh, I. and Schleinzer G., “Investigation into the indirect determination of wheel-rail surface roughness”, in: *Proceedings of the 11th Mini Conference on Vehicle System Dynamics, Identification and anomalies*, Budapest, pp. 135–146, 2008

System for IOT Measurements of Ride Comfort

Lars-Ove Jönsson¹

¹ Analytical Dynamics AB, Lund, Sweden, lars-ove.jonsson@anadyn.se

The availability of affordable sensors and internet access has made the continuous measurement of operational parameters possible, known as Internet of Things or IOT. In this talk a system for IOT measurements of ride comfort of passenger trains by Analytical Dynamics will be presented. In each measuring node the carbody accelerations and gyro signals are registered, together with vehicle speed and location by means of GPS.

The measurements themselves are a minor part of any IOT system, which quickly becomes evident by anyone attempting to implement such a system. Without an intelligent system for postprocessing and condensing the acquired data it is of very little value. The IOT system by Analytical Dynamics automatically handles the incoming data, with positioning and calculation of ride comfort indexes. Furthermore, the process is lossless; the raw data is kept for detailed analysis of individual events. It has been in continuous operation for 7 years.

An example of postprocessed data is shown in Figure. The upper diagram shows daily statistics of a lateral ride comfort index, where the green line shows the median value, the orange line the 95% percentile and the blue line the daily maximum. The lower diagram shows the maximum value per day, but along the track. Darker colours indicate higher values. The diagrams summarize 420 000 km of measurements collected over 3.5 years.

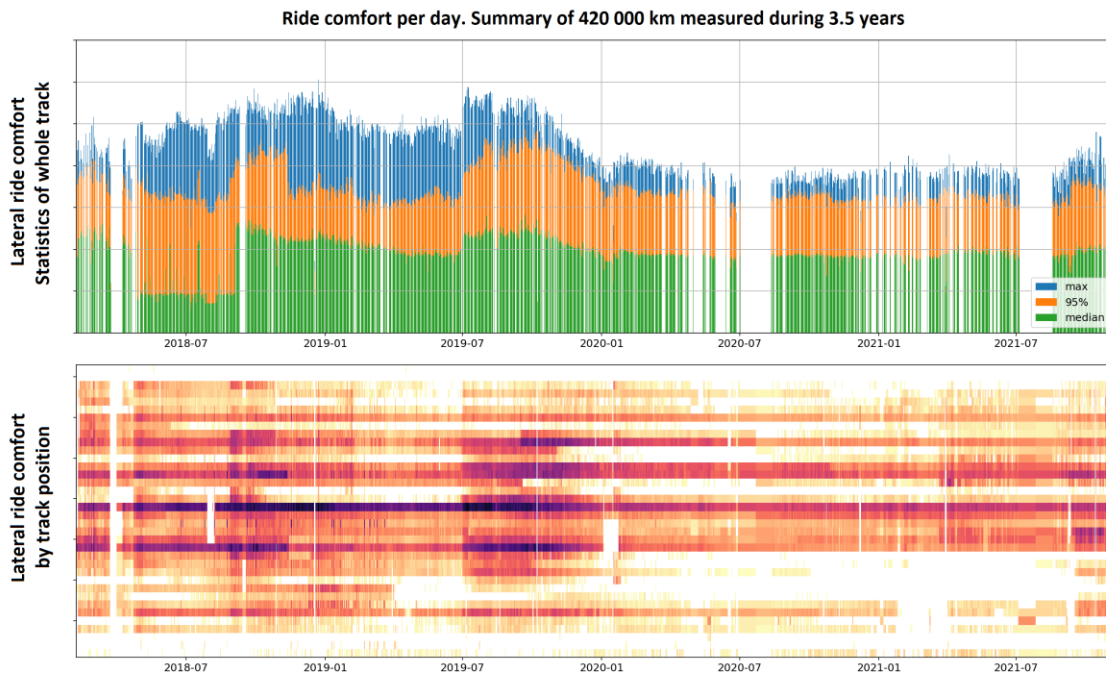

Figure 1. Example of ride comfort evaluation. Data collected over 3.5 years and 420 000 km.

Multi-Source Railway Condition Data Analysis for Optimized Track Maintenance Planning

M. Silvast¹

¹Loram Finland Oy, Tampere, Finland. mika.a.silvast@loram.com

Introduction

Rail networks around the world are experiencing increased traffic, heavier axle loads and seasonal changes, as well as the diverse needs of freight and passenger trains. This sets a large burden on railway structures. Concurrently, budgets and time slots for maintenance and rehabilitation works have decreased. For that reason, optimized track maintenance planning and rehabilitation decisions are essential for effectively managing track condition and its life cycle costs.

Analysis

This presentation introduces experiences with an innovative analysis method that has been developed for effective track rehabilitation and maintenance planning in Finnish rail network. The method integrates condition data from multiple sources, including track geometry measurements describing the functional condition of the track, LiDAR measurements illustrating track environment characteristics and ground-penetrating radar (GPR) measurements providing information about structural conditions below the surface.

Conclusions

Analysis of the integrated multi-source data leads to more accurate and detailed maintenance decisions. Track maintenance budgets can be correctly allocated based on improved knowledge of the maintenance needed, combined with the known state of the rail network.

References

Silvast, M., Nurmikolu, A., Wiljanen, B., Mäkelä, E. 2017. Semi-automatic condition-based track maintenance and rehabilitation planning. Proceedings of the 11th International Heavy Haul Conference, September 2-6, 2017, Cape Town, South Africa.

Bayesian Statistics for Fleet Management of Rolling Stock

Jaya Kumari*¹, Ramin Karim*² and Miguel Castaño Arranz*³

*Department of Civil, Environmental and Natural Resources Engineering, Division of Operation and Maintenance, Luleå, Sweden

¹ jaya.kumari@ltu.se, ² ramin.karim@ltu.se, ³ miguel.castano @ltu.se

Introduction

To achieve operational excellence in railways, there is need for effective and efficient Asset Management (AM). The Asset Management approach when applied to the Fleet Management of rolling stock in railways requires a holistic picture of the fleet that involves the general fleet behaviour as well as the individual behaviour of the outliers in the fleet [1]. The railway stakeholders such as train owners, operators, maintenance service providers and infrastructure managers face challenges in identifying the bottlenecks in the operation of the fleet, and the parties that are responsible for these bottlenecks. Utilising the learning from the fleet behaviour to identify the behaviour of individual vehicles in the fleet and vice versa can help identify these bottlenecks in fleet operation.

Analysis

Data driven analytics requires sufficient data to represent the asset condition. The fleet of rolling stock consists of a number of individual vehicles. Therefore, there are sufficient data points consisting of failure and maintenance history of the entire fleet, to draw a failure distribution for a fleet of railway vehicles. This knowledge on the fleet behaviour can be used as a prior distribution, for individual vehicles in the fleet, which have comparatively fewer data points that are not enough to draw a failure distribution. In this work, Hierarchical Bayesian Modelling is applied to estimate the distribution of failures in individual vehicles, based on the failure distribution of the entire fleet.

Conclusions

The proposed method enables the estimation of failure distribution for vehicles in the fleet even when there is insufficient data. This estimation can lead to identification of the vehicles that might have a significant impact on the overall fleet performance. This will help in the identification of bottlenecks in the fleet operation, and contribute to an efficient and effective AM.

References

- [1] J. Kumari, R. Karim, A. Thaduri, M. Castano, Augmented asset management in railways – Issues and challenges in rolling stock, Proc. Inst. Mech. Eng. Part F J. Rail Rapid Transit. (2021). <https://doi.org/10.1177/09544097211045782>.

A Backpropagation Algorithm for use of Renewable Energy along Railway Lines

Angelo Compierchio¹, Phillip Tretten¹

¹ Operation and Maintenance Engineering,
Department of Civil, Environmental and Natural Resources Engineering,
Luleå University of Technology
SE - 97187 Luleå, Sweden
{Angelo.Compierchio, Phillip.Tretten} @LTU.se

Introduction

Energy efficiency improvements along railway lines is essential to meet renewed environmental and market demands of the Swedish railway. The further increase of energy efficiency from a power station to renewable energy utilization is investigated along the Umeå to Stockholm line. A backpropagation unsupervised adaptation algorithm is introduced to exhibits electrical load cyclical behaviour between stations. The realization of an integrated energy system network enables reduction of energy consumption through the use of renewable energy and improvement of the quality of railway services.

Analysis

An availability analysis is performed to identify potential renewable energy sources such as photovoltaic, wind power and biomass. Sizing of the source is performed according to railway needs with monitoring systems connecting traffic regulators within the train cockpit. Integration is performed on board and on land through regulators probing crossing and train precedence. The integrated architecture includes a control system of energy generation and utilization. The backpropagation learning algorithm adapts to regularities in the data (Reed and Marks 1999) according to the electricity required for the operation of railway systems with the inclusion of renewable energy.

Conclusions

The assessment of energy utilization is performed from the motion of the train captured downhill, uphill and on flat land. Since power plants are sized for maximum loads the exchanged energy for lower electrical loads is compensated with renewable energy available. The optimal use of the remaining energy available can then be directed towards other industrial or social uses.



Figure 1. Umea to Stockholm railway track. (www.moovitapp.com)

Statistical analysis of curve squeal based on long-term onboard noise measurements

Olle Eriksson¹, Peter T. Torstensson¹, Astrid Pieringer², Rickard Nilsson³, Martin Höjer⁴, Matthias Asplund⁵
and Anna Świerkoska⁶

¹ Swedish National Road and Transport Research Institute (VTI), Sweden

² Chalmers University of Technology, Department of Architecture and Civil Engineering, Division of Applied Acoustics/CHARMEC, Gothenburg, Sweden

³ Stockholm Public Transport (SL), Stockholm, Sweden

⁴ Tyréns Solutions AB, Stockholm, Sweden

⁵ Swedish Transport Administration (Trafikverket), Borlänge, Sweden

⁶ Sieć Badawcza Łukasiewicz, Railway Vehicles Institute “TABOR”, Poznań, Poland

Introduction

Curve squeal with large magnitude tonal components in the frequency range up to 10 kHz is a cause of annoyance without any satisfying solution. This might be partly due to the gaps in the current understanding of the phenomenon within the research community (e.g. the open question whether the fundamental excitation mechanism is due to “falling friction” or “modal coupling”). Rail-bound traffic is expected to become a backbone in the future sustainable public transportation system. This makes it urgent to increase the state of knowledge in order to develop effective mitigation measures against the problem.

Analysis

Noise recorded by an onboard monitoring system during one year of traffic on the Stockholm metro is studied. The influence of selected variables on the generation of curve squeal is investigated in a statistical assessment. The influence of curve radius on curve squeal probability is estimated by calculating the quotient of squealing samples with respect to the total number of samples captured in circular curve sections. Vehicle speed (operative conditions) is modelled by the introduction of a classification representing different speed profiles (e.g. constant, linear acceleration or deceleration, etc.). Environmental conditions are accounted for by using humidity and air temperature as predictor variables.

Conclusions

A general trend of increased probability of curve squeal for decreasing curve radius is observed. Several subsequent regression analyses could not find a consistent influence of air temperature and humidity on the occurrence of curve squeal. Moreover, preliminary results indicate the existence of a vehicle speed for which a curve is particularly prone to generate squeal noise.

Overhead contact wire wear: a heuristic model for Norwegian conditions

S. Derosa¹, P. Nåvik¹, A. Collina², G. Bucca² and A. Rønnquist¹

¹Department of Structural Engineering, NTNU, Trondheim, Norway. stefano.derosa@ntnu.no

²Department of Mechanical Engineering, Politecnico di Milano, Milan, Italy.

Introduction

For electric railways, one of the most important aspect to be considered is the interaction between the pantograph and the catenary infrastructure. A phenomenon that cannot be avoided is the wear of the elements that realize the sliding contact between the pantograph and the contact wire. Many studies analysed how this wear evolves, including both the effects of materials (Borgwardt 1989) and operational parameters (Klapas et al. 1988). A model that includes all the components that affect the wear and that depends on these parameters can then be created. In this way, it is possible to estimate the wear under existing or new conditions. In this work, the Norwegian case is taken into consideration, with the creation of a model based on extensive laboratory testing based on the parameters in use on the Norwegian Railway Network.

Analysis

The tests have been designed to investigate the wear assigning to the parameters of contact force, electric current intensity and train speed both values commonly used within the Norwegian Railways, and values that are an anticipation of future applications. Wear measurements for all the cases have then been fitted with an equation that include all the mechanical and electrical effects that influence the wear (Bucca and Collina 2015).

Conclusions

The surface plotted in Figure 10 (Derosa et al. 2020) shows the curve represented by the chosen equation fitted to the measured points. With this model, it is possible to have a relation between operational parameters and wear rate, giving the possibility to predict the wear of the wire on a long-term time horizon.

Figure 1. NWR surface and measured data.

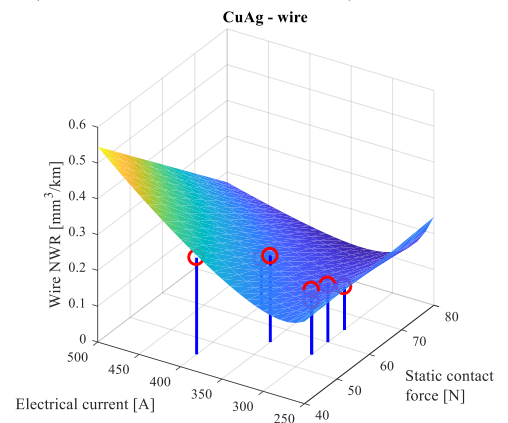

References

- Borgwardt, Horst. 1989. "Verschleiß Verhalten Des Fahrdraht Der Oberleitung." *Elektrische Bahnen* 87(10):287–95.
- Bucca, Giuseppe and Andrea Collina. 2015. "Electromechanical Interaction between Carbon-Based Pantograph Strip and Copper Contact Wire: A Heuristic Wear Model." *Tribology International* 92:47–56.
- Derosa, Stefano, Petter Nåvik, Andrea Collina, Giuseppe Bucca, and Anders Rønnquist. 2020. "A Heuristic Wear Model for the Contact Strip and Contact Wire in Pantograph – Catenary Interaction for Railway Operations under 15 KV 16.67 Hz AC Systems." *Wear* 457:203401.
- Klapas, D., F. A. Benson, R. Hackam, and P. R. Evison. 1988. "Wear in Simulated Railway Overhead Current Collection Systems." *Wear* 126(2):167–90.

Modelling the railway induced ground vibrations in soft soil areas of Western Finland

Mr. Antti Pelho¹, Dr. Juho Mansikkamäki² and Dr. Matti Hakulinen³

¹ AFRY Finland Oy, Tampere, Finland. antti.pelho@poyry.com

² AFRY Finland Oy, Tampere, Finland. juho.mansikkamaki@poyry.com

³ AFRY Finland Oy, Tampere, Finland. matti.hakulinen@poyry.com

Introduction

The vibrations induced by railway are a major problem in soft soil areas. The vibrations can be harmful for the structures of the buildings, but commonly they are affecting the areas comfort of living.

In last couple of years in western Finland the railway induced vibrations started to disturb the residents of the area. Finnish Transportation Infrastructure Agency (FTIA) started to investigate the problem and organized massive test drives in the Kokemäki-Pori railway. The rolling stock was brought from Russia, because the disturbing vibration started at the same time as heavy coal transportation from Russia to the port of Pori. The test trains were driven in four different speeds from 40 km/h to 70 km/h as fully-loaded and in five different speeds from 40km/h to 80 km/h as empty.

Two sites were chosen to be instrumented with monitoring equipment. The ground vibrations in different distances from the railroad, the deflection of railroad and the vertical and horizontal forces affecting the rail by trains were measured in test sites.

Analysis

AFRY Finland Oy conducted dynamic Plaxis 2D FE analyses for both the test sites. The FE model was used to calculate the vibration of soft soils based on the available soil data and compared to the measured data achieved from the test drives. The model used the measured deflection of the sleeper as the impulse which causes vibration to the ground. The soil parameters were estimated from old soil investigations from both test sites.

The goal of this study was to understand the vibrations functions and causes with the model. How and why the wave propagates and dampens as measured and how the trains speed affects the vibrations.

Conclusions

The 2D FE model can be used to approximate the soils natural frequency if the soil investigations of the area are extensive. If the natural frequency of soil layer and the driving frequency of train load are close to each other the vibrations will resonate and the amplitude will grow. If the frequencies are far apart the vibrations will diminish faster.

The train speed affects to the driving frequency and that way to the measured and modelled vibrations. The model can be used to simulate the possible resonance of the soils natural frequency and the trains driving frequency, which can be used to locate the critical speeds of certain rolling stock, which could cause harmful vibrations to the areas near railway.

Vibration insulation solutions for track structures: the important role of insertion loss for specifications

Dr Amy P. de Man¹

¹ Knowledge Centre, edilon)(sedra bv, Haarlem, the Netherlands. ap.d.man@edilonsedra.com

Introduction

This paper addresses the widely supported need for workable specifications on vibration insulation performance of track structures. There is no doubt that the well-being and health of people as well as the operational performance of machines and equipment can suffer from vibrations induced by rail bound transport systems. Multiple measures have been developed over time to overcome vibration hindrance. But still there is a need to build closer to tracks, and to run trains more frequently and at higher speed. See here the problem.

Analysis

Insertion loss is a term widely used in specifications to describe vibration reduction in favour of people and machines. But the exact meaning of insertion loss is often misinterpreted. And so is the understanding of what insertion loss can contribute to solutions to effectively reduce vibrations.

Conclusions

Based on standards (e.g. DIN 45673-1 and subsequent parts), computer tools and experiences this paper will contain useful information to improve specifications and to link these to generally available track solutions.

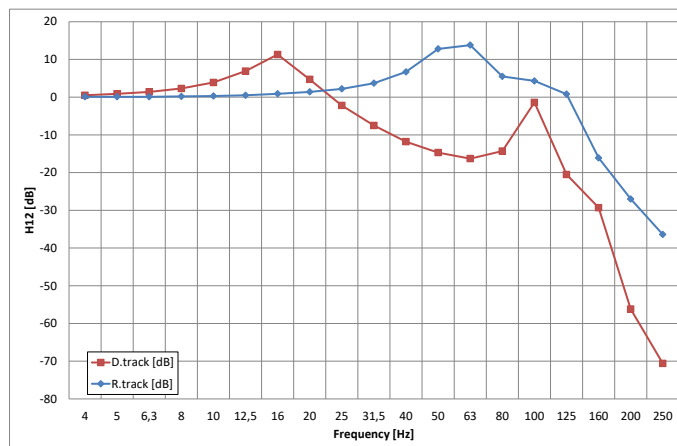

Figure 2. Typical examples of transfer functions for modelled floating slab and non-floating slab, enabling insertion loss calculation

References

DIN 45673-1 Mechanical vibration – Resilient elements used in railway tracks – Part 1: Terms and definitions, classification, test procedures, August 2010.

Noise and vibration mitigation on low-vibration track

Jannik Theysen, Astrid Pieringer and Wolfgang Kropp

Applied Acoustics, Chalmers University of Technology, Gothenburg, Sweden. Jannik.theysen@chalmers.se

Slab-track technology is increasingly being used to build high-speed railway lines around the world. In slab tracks, a reinforced concrete slab replaces the supporting function of traditional ballast and sleepers. The expanding use is attributed in part to their lower maintenance and potential for efficient ground-borne vibration isolation. Rolling noise on slab tracks, on the other hand, often has higher levels of noise radiation than ballasted rails. There appears to be a conflict between ground-borne vibration and noise: the stiffness of the rail support influences whether vibrational energy is transmitted into the ground, causing ground-borne vibrations, or remains in the rail, causing increased noise emission. In this study, a slab track construction type known as low-vibration track (Figure 1), is modified with the goal of lowering both vibrations and noise radiation.



Figure 3. Left: Track with booted sleepers in Malmö, right: construction of the sleeper and boot.

This is accomplished by tuning the elasticities surrounding the booted sleeper to give low support stiffness at low frequencies and high stiffness in the range where the rail has a high radiation efficiency. The effect of the different stiffnesses on the noise emitted by the rail and track is simulated using a combined waveguide Finite Element and Boundary Element method. Further, the effect of the increased rail support stiffness at high frequencies on the contact forces is analysed.

A parameter study shows that by tuning the involved elasticities and the sleeper mass, the noise can be reduced while the stiffness of a typical low-vibration track is maintained.

References

- Hemsworth, B., "Reducing Groundborne Vibrations: State of the art study", *Journal of Sound and Vibration*, vol. 231, pp. 703–709, Mar. 2000.
- Nilsson C.-M., Jones, C., Thompson, D., and Ryue, J., "A waveguide finite element and boundary element approach to calculating the sound radiated by railway and tram rails," *Journal of Sound and Vibration*, vol. 321, pp. 813–836, Apr. 2009.
- Jones, C., Thompson, D., and Diehl, R., "The use of decay rates to analyse the performance of railway track in rolling noise generation", *Journal of Sound and Vibration*, vol. 293, pp. 485–495, June 2006.

Comparison of the dynamic response between traditional and innovative railway track systems

Emil Aggestam¹ and Jens C. O. Nielsen²

¹ UHtsp1, Trafikverket, SE-411 04, Gothenburg, Sweden.

² Department of Mechanics and Maritime Sciences, Chalmers University of Technology, SE-412 96, Gothenburg, Sweden.
emil.aggstam@chalmers.se

Railway infrastructure may include a range of different track forms. In this study, a ballasted track design has been compared to three different slab track solutions. These include one design that is used in commercial service today (ST), one design that has been optimised based on the European standard 16432-2 (EN) and considering environmental impact, and one type that can be described as a ladder structure (3MB). The tracks are compared using a methodology for simulation of three-dimensional vertical dynamic vehicle–track interaction.

For the investigated load cases involving representative wheel and track irregularities, it is concluded that the maximum stress in the concrete parts is, for all designs, below the maximum flexural tensile strength. In Figure 1, the spatial distribution of maximum pressure on the supporting foundation is shown. Since different rail irregularities are applied on the two rails, the wheel–rail excitation is non-symmetric. By comparing the scale of the colour bars between the different designs, it is concluded that the pressure levels are significantly higher for the ballasted track design and the ladder track design, which increases the risk of track settlement.

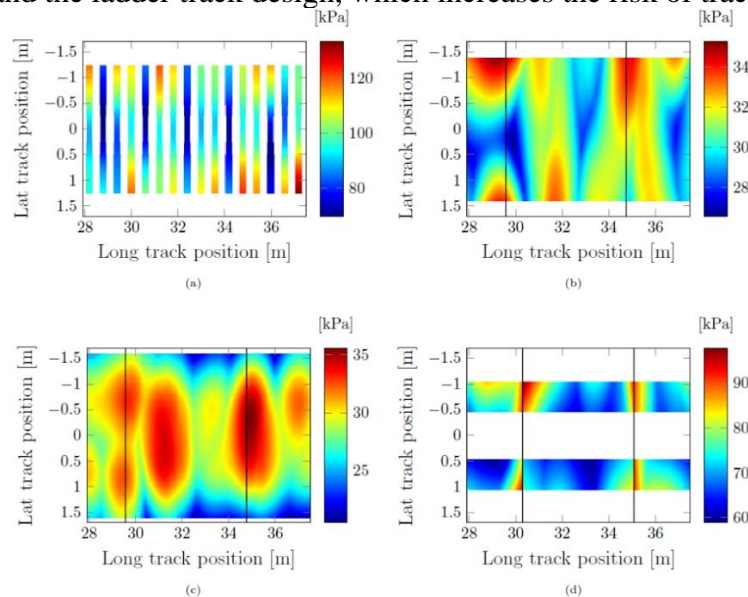

Figure 1. Distribution of maximum pressure on the supporting foundation for (a) ballasted track design (b) STA design (c) EN design and (d) 3MB design.

References

Aggestam E, Nielsen JCO, Lundgren K, Zandi K and Ekberg, A. Optimisation of slab track design considering dynamic train–track interaction and environmental impact. *Engineering Structures*, vol. 254, 2022.

Evaluation methods and in-situ measurements of Ground Vibration Boom

Heikki Luomala¹, Teemu Partanen¹, Riku Varis ja Tommi Rantala¹

¹ TerraRail, Tampere University, Tampere, Finland. heikki.luomala@tuni.fi

Ground vibration boom is a phenomenon of very large increase in ground vibrations generated by high-speed railway trains travelling at speeds of the Rayleigh surface wave velocity in the supporting ground. The phenomenon begins to arise after trains travelling speed approaches 60-70 percent of Rayleigh velocity. Often the possibility of the phenomena is evaluated based on shear wave velocity that is close to that of Rayleigh velocity, but simpler to determine.

Rantarata line in Southern Finland have been rehabilitated for higher speeds. Before taking the higher speed in commercial use, the test runs were organized to make sure that the railway is safe to operate. Tampere University was responsible conducting measurements on soft soil areas where ground vibration boom might be possible to occur. One part of the study was the preliminary tests where the shear wave velocities were measured on site. This part was carried out in Teemu Partanen's Master Thesis (Partanen 2020). Another part of the study was the direct measurements of displacements during the test runs. In the preliminary tests, a few locations were identified where the ground vibration boom could be possible at relative low travelling speeds such as 180 km/h. These locations were instrumented with accelerometers and displacement transducers. Figure 1 presents results of displacements in location 129+400. The Sm3 represents the Pendolino train with axle load of 140 kN and the IC2 represents the locomotive's axle load of 210 kN from the Intercity train. The results showed that the ground vibration boom was approached slightly with both train types with the highest speeds in the tests. Based on results a speed limit 180 km/h was proposed to IC2 trains and 200 km/h to Sm3 trains.

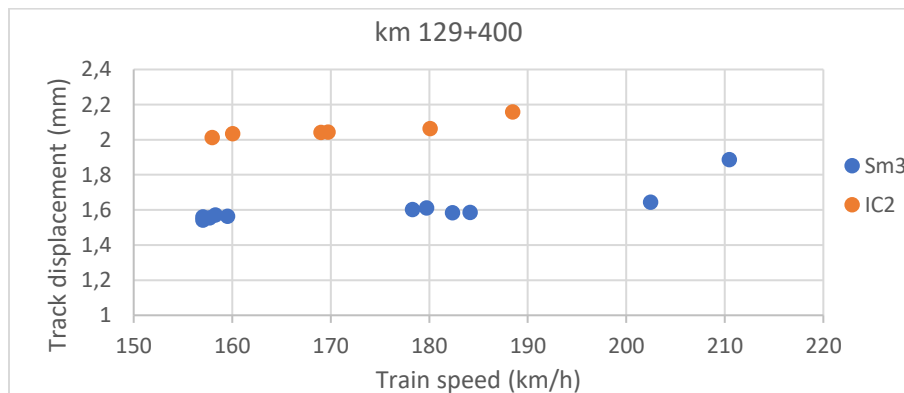

Figure 4. Displacement measurements at different speed in Rantarata line km 129+400.

References

Partanen T. (2020). Evaluating the risk of ground vibrations caused by high-speed trains. Master's thesis, Tampere University. Available at <https://urn.fi/URN:NBN:fi:tuni-202011198104> (in Finnish)

Predicting RCF Crack Initiation in Rails using Critical Plane Fatigue Damage Parameters

Jonathan F.W. Leung^{1,2}, Saeed Hossein Nia¹, Carlos Casanueva Perez¹, Mårten Olsson²

¹ Rail Vehicles, Department of Engineering Mechanics, KTH Royal Institute of Technology, Stockholm, SE

² Solid Mechanics, Department of Engineering Mechanics, KTH Royal Institute of Technology, Stockholm, SE

Corresponding email: jleung@kth.se

Rolling contact fatigue (RCF) crack formation is a significant issue faced by global rail networks. Understanding the relationship between operating, infrastructure, and vehicle conditions on RCF crack initiation is critical in developing improved operating limits and predictive maintenance standards for rails. Current RCF assessments utilize multibody simulation (MBS) packages and the shakedown limit to predict rail surface crack formation; however, these existing models require prior information on expected crack orientation and crack depth to predict RCF damage. Moreover, these models do not capture the effect of local stress on crack initiation location and crack orientation.

This work outlines a new multiscale computational framework that couples multibody simulation (MBS) with finite element (FE) analysis to assess the RCF crack formation based on damage evolution predicted by multiaxial critical plane approaches. Critical plane approaches predict crack formation on planes at material points where the fatigue damage parameter is maximum. As shown in Figure 1, this new framework samples the MBS loading spectrum at given gross tonnage increments (MGT_{inv}) as inputs for FE simulations, thus reducing the computational expense of FE simulation while capturing the stochastic influence of railway dynamics parameters on RCF crack initiation. The framework calculates each increment's fatigue damage parameter and critical plane. Comparisons of the accumulated damage progression to current shakedown limit approaches are discussed to highlight the role of critical plane techniques within the RCF crack prediction assessment tools.

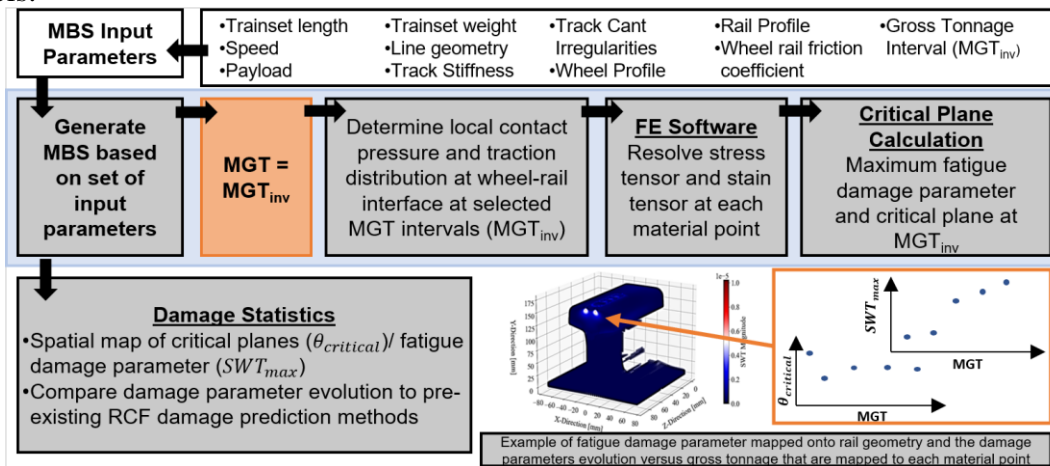

Figure 1. Computational Methodology flowchart for integrating MBS with Critical Plane Fatigue Damage Analysis

Statistical analysis of railway rail wear measurements

J. Rajamäki¹

¹, Sweco PM Oy, Helsinki, juho.rajamaki@sweco.fi

Wear and rolling contact fatigue (RCF) are both major causes of rail replacement and therefore predicting them is important. Predictions should be both accurate and easy in order to help decision making.

A study on rail wear and RCF was conducted in Finnish railway environment, but the focus of this presentation is on rail wear alone. The aim of the research was to produce better tools for estimating rail durability in Finnish railway environment and to check the long-standing presumptions of rail durability against accurate measurements and methodologically rigorous statistical testing. Since the goal was to test presumptions, an inductive approach in both measuring and modelling was selected.

Rail wear was measured with a mechanical contact measurement device and RCF was measured with eddy current device from multiple locations on Finnish railway network. The measurement sites (curve) were selected so that they represent evenly different curve and load parameters present in Finnish network.

A correction to wear measurement was developed during the study and the corrected wear rate was used in the analysis. Eddy current amplitude was used as a measure of crack growth rate. The amplitude was not converted to crack length, since it was discovered that this would distort inference and the amplitude represent damage severity better than the crack length would.

The modelling process was conducted in five steps. In the first step, all likely parameter were added to a parameter pool and all possible models were estimated from this pool. In the process, around 3,5 million models were estimated. The rest of the modelling concentrated on eliminating unnecessary variables and testing of model presumption.

During modelling, it was discovered that not all rails develop wear over use. It is paramount for modelling to account for this or the results of statistical analysis will become biased. Therefore, modelling was done by logistic and linear regression, where the former modelled the probability of no wear and the latter the amount of wear. It was discovered that the most influential factor that predict when a rail will develop wear were logarithm of tonnage, velocity of passenger traffic, and curve radius. The amount of wear was best predicted by inverse of curve radius, square polynomial of curve length, position of measurement inside a curve, cant, cant deficiency of freight traffic, speed of track and rail age.

The direction of effects was as expected, except for velocity of passenger traffic that was opposite of expected. It was discovered that the position of measurement inside a curve had a tremendous effect on wear and this created problems in modelling, since track geometry factors tend to be constant over a curve.

In addition, the effect of rail wear on RCF was studied. The data had no indication that the wear rate would have any effect on the amount of RCF. This contrasts with the commonly held belief that rail wear would mitigate RCF.

Simulation and field tests of long term rail profile damage in a curve due to plasticity, wear and surface crack initiation

Caroline Ansin^{1*}, Björn A. Pålsson², Magnus Ekh¹, Fredrik Larsson¹, and Ragnar Larsson¹

¹ Department of Industrial and Materials Science/CHARMEC

² Department of Mechanics and Maritime Sciences/CHARMEC

Chalmers University of Technology, SE-412 96 Gothenburg, Sweden

*E-mail: caroline.ansin@chalmers.se

Curved tracks are subjected to high lateral contact forces between wheel and rail, causing damage to the railhead. Due to the high costs associated with rail damage in curves, it is imperative to perform cost-effective maintenance and to extend rail life. This, in turn, can benefit from accurate predictions of the pertinent damage mechanisms for different operational conditions.

The current study focuses on the modelling and simulation of the long-term rail damage in a cross-section of a curve for a given traffic scenario. The simulations are validated and compared against experimental profile measurements from field tests, illustrating the potential of the procedure.

The numerical methodology is illustrated in Figure 1 and was proposed by Johansson et al. (2011) and modified by Skrypnik et al. (2021). It includes multibody dynamics simulations for a given traffic scenario, elasto-plastic contact analyses, and the modelling of cyclic plasticity, wear and surface rolling contact fatigue. Lastly, the accumulated effect of plastic deformation and wear is quantified, and the updated rail profile is used as an input for the dynamic simulation in the next iteration of the simulation methodology.

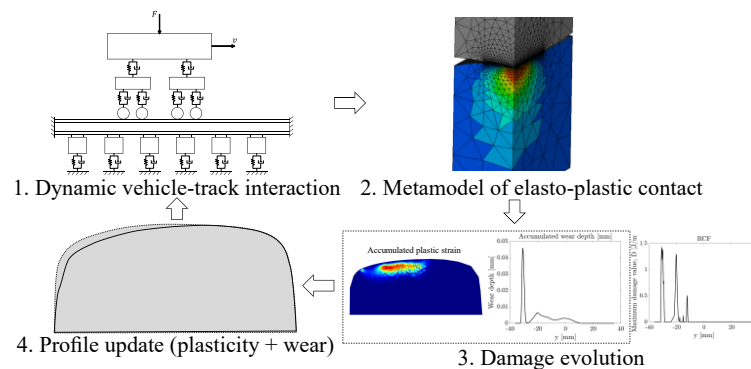

Figure 1. Steps of the iterative simulation tool of the numerical model to determine the damage evolution due to plasticity and wear as well as the initiation of rolling contact fatigue.

References

Johansson, A., Pålsson, B., Ekh, M., Nielsen, J. C. O., Ander, M. K. A., Brouzoulis, J., & Kassa, E. (2011). Simulation of wheel-rail contact and damage in switches & crossings. *Wear*, 271(1), 472–481.

<https://doi.org/10.1016/j.wear.2010.10.014>

Skrypnik, R., Pålsson, B. A., Nielsen, J. C. O., & Ekh, M. (2021). On the influence of crossing angle on long-term rail damage evolution in railway crossings. *International Journal of Rail Transportation*, 0(0), 1–17.

<https://doi.org/10.1080/23248378.2020.1864794>

Crack initiation criteria for deformed anisotropic R260 rail steel

Nasrin Talebi¹, Johan Alström¹, Magnus Ekh¹, Knut Andreas Meyer²

¹ Department of Industrial and Material Sciences, Chalmers University of Technology, 41296 Göteborg, Sweden

² Institute of Applied Mechanics, TU Braunschweig, 38106 Braunschweig, Germany
nasrint@chalmers.se

Rolling Contact Fatigue crack initiation is often connected to the accumulation of plastic deformation in the surface layer of rails and wheels. The behavior and strength of this highly deformed and anisotropic layer are thus key properties of a rail or wheel material. These properties also change with traffic, since the anisotropic layer evolves both in terms of depth and degree of anisotropy. Establishing crack initiation models that are experimentally validated is of great importance in railway engineering to increase reliability in maintenance action planning and actions to improve traffic safety.

A great challenge is to measure these properties. One example of contribution in literature is Meyer et. al, in which an axial-torsion machine was used to apply an axial loading combined with large shear deformations to R260 steel. It was found that the deformed steel in the specimens had similar properties as found in the anisotropic surface layer of field samples. An advantage of this technique is that cyclic loading can be conducted combined with large shear deformations.

Various crack initiation criteria for rolling-contact situations have been proposed in the literature. An example of such a criterion is formulated by Kapoor, where the von Mises equivalent ratcheting strain in each loading cycle contributes to the damage evolution. Others use the critical plane approach, such as in Dang Van et. al. In Jiang and Sehitoglu, a criterion combining the critical plane approach and the ratcheting strain is proposed. The limitation of the above-mentioned criteria is that they do not account for the anisotropy, which is very important for rolling contact fatigue.

In this contribution, we aim to model the cyclic plasticity and anisotropy development by using the material model proposed in Meyer and Menzel in a finite element model of the tension-torsion tests. By using the stress and strain histories, various fatigue initiation criteria can be applied and evaluated against experimental data.

References

- K. A. Meyer, D. Nikas, and J. Ahlström “Microstructure and mechanical properties of the running band in a pearlitic rail steel: Comparison between biaxially deformed steel and field samples”, *Wear*, 2018, 396-397 12–21
- A. Kapoor: A Re-Evaluation of the Life to Rupture of Ductile Metals by Cyclic Plastic Strain, *Fatigue & Fracture of Engineering Materials and Structures*, 1994, 17(2) 201-219
- K. Dang Van, M.H. Maitournam, Z. Moumni, and F. Roger: A comprehensive approach for modeling fatigue and fracture of rails, *Engineering Fracture Mechanics*, 2009, 76(17) 2626-2636
- Y. Jiang and H. Sehitoglu: A model for rolling contact failure, *Wear*, 1999, 224(1) 38–49
- K. A. Meyer and A. Menzel: A distortional hardening model for finite plasticity, *International Journal of Solids and Structures*, 2021, 232 111055

Track Experiences with 400GHT[®] Grooved Rails

Lukas Prettner

¹ Productmanagement, voestalpine Schienen, Leoben, Austria. lukas.prettner@voestalpine.com

P203

400GHT[®] - A new rail steel for grooved rail tracks

In view of future demands on availability and profitability of urban tramway track that is driven by increasing urbanization and the public desire for 24/7 mobility, the new grooved rail steel 400GHT[®] has been developed. The rail steel 400GHT[®] follows a put-in-&-forget maintenance approach, where Gauge Corner Repair welding is totally avoided, while reaching longest possible service lives even in curves.

Track Performance

Based on track experiences from Vienna, Berlin and Warsaw the material behaviour of 400GHT[®] grooved rail steel is demonstrated in comparison to other state of the art rail steels. Measurement results suggest that the service lives of R200 and R290GHT rail steel will be exceeded in all cases without the need for Gauge Corner Repair welding. The slower development of corrugation is a further performance attribute of 400GHT[®] leading ultimately to a durable silent track with lowest demands on rail maintenance.

Conclusions

The prolonged service life and the low maintenance concept of 400GHT[®] offer a vast potential of Life Cycle cost reduction and eliminate at the same time the risk of potential failures from Gauge Corner Repair welding in track. Ultimately the long service life reduces the need for rail renewal, leading to a significant reduction of CO₂ footprint of the infrastructure.

Summarising, highest economic and ecological benefits can be achieved by using 400GHT[®] in urban tramway track.

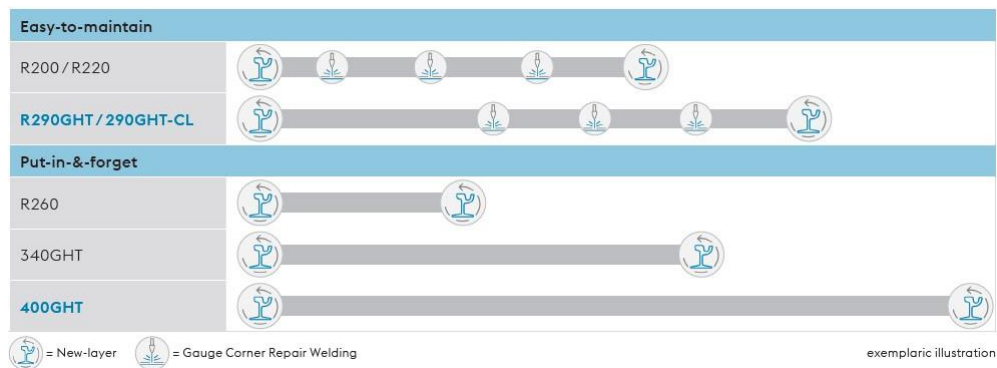

Figure 1. Exemplary illustration of expected track service lives and maintenance cycles in curves. (1)

References

- (1) Prettner L., Hammer T., “Erste Betriebserfahrungen mit wärmebehandelten Rillenschienen der Güte 400GHT im Netz der Wiener Linien“, ZEVrail, Linz, 2019 Issue 143, pp.439–445

Prediction of Wheel-Wear for a Metro Vehicle

B. de Leeuw¹, S. Hossein-Nia² and S. Stichel³

¹ Rail Vehicles, KTH, Stockholm, Stockholm. bentedi@kth.se

² Rail Vehicles, KTH, Stockholm, Stockholm. nsho@kth.se

³ Rail Vehicles, KTH, Stockholm, Stockholm. stichel@kth.se

Recently the railway operators have started converting from conventional maintenance planning to predictive maintenance planning. For this to succeed an accurate prediction of failure and operation limits is required. In this project the running distance of the wheels of a typical 6-car metro vehicle, hereafter called Vehicle M, is predicted by using multi-body simulations. The running distance then gives the distance after which the wheels should be reprofiled to guarantee a safe and comfortable operation.

The used methodology for the multi-body dynamics is given in Figure 1. **Error! Reference source not found.** Since no measured worn rail profiles are available, first simulations are performed to create a worn rail profile. The profile has been created with vehicle M running in a 200-meter curve for 6 months. The final rail profile is then used as input for the simulations for the wheel wear and RCF.

To determine the wheel-wear and RCF the analysed track has been separated into four sections: small curves, average curves, wide curves, and tangent track. After each wear step the wheel profile is updated with the calculated wear, the RCF depth is gathered separately and added to the depth of the previous wear step. For the calculation of the wear and RCF the FaStrip algorithm [1] has been used. The use of traction and braking has been implemented into the multi-body simulation. Each curve section has been divided into three situations: acceleration, constant speed, and braking. The acceleration and deceleration represent the stops that vehicle M makes while running in a real-life scenario.

The SS-EN 15313:2016 gives the maximum flange height, inclination and width, which are the limiting factors for the in-service wheelsets. When the limits are reached, the wheel needs to be reprofiled and thus the running distance can be determined. In Figure 2 the preliminary results are given. The wheel evolution is given for a running distance up to 96,194km, which gives a maximum wear depth of 1.23mm.

References

Hossein-Nia, S., Sichani, M. S., Stichel, S., & Casanueva, C. (2018). Wheel life prediction model—an alternative to the FASTSIM algorithm for RCF. *Vehicle System Dynamics*, 56(7), 1051–1071. [1]

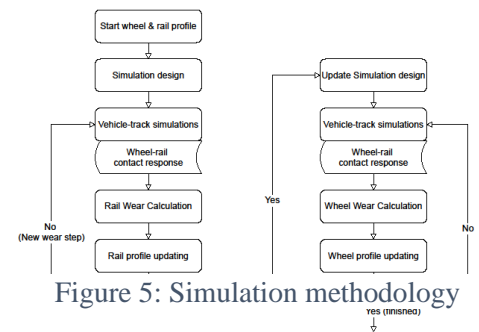

Figure 5: Simulation methodology

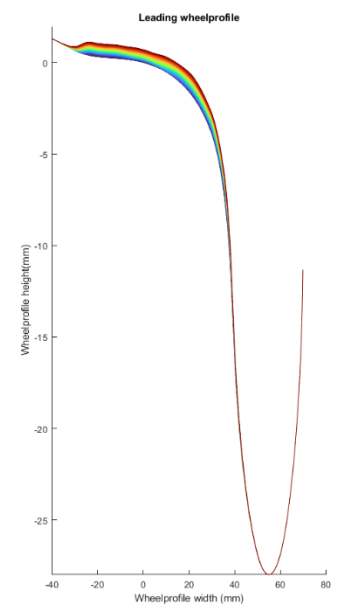

Figure 6: Wheel evolution

Service life of wheels on regional trains

Magnus Lundgren, Atkins Sweden AB

ABSTRACT

Traditionally wheel turning intervals - and by that the service life of the wheels - is determined by the wheel flange dimensions. These flange measures are normally taken at one of the regular overhaul intervals and are compared to the limit values from the maintenance instruction. These limit values are based on the European Standard.

Rolling stock of today equipped with passive radial steered bogies and modern propulsion system causes however a wear pattern that deviates from the traditional one such as flange wear. Equivalent conicity from hollow tread wear as well as rolling contact fatigue injuries have become more relevant measures than the traditional wheel profile dimensions. Higher speeds and higher axle load in combination with smaller wheels - due to low floor requirements - contributes also to this new type of wear and damages.

This presentation illustrates that the traditional limit values for the wheel flange dimensions do not fully capture this kind of wear and that the equivalent conicity due to instable running has become a more precise value to determine when to turn the wheels. Also, the presence of injuries from rolling contact fatigue can have a major impact to the wheel turning frequency.

Results from wheel profile measurements and wheel tread inspections from two types of regional trains in Sweden that have been carried out and followed during a couple of years are shown. These results show that the equivalent conicity and other wheel tread damages set the limit for wheel life. One conclusion is also that there is no obvious correlation between the conicity and the traditional wheel profile limit dimensions.

Influence of wheel and rail deterioration on wheelset fatigue life

Michele Maglio¹, Elena Kabo¹, Anders Ekberg¹

¹ CHARMEC / Department of Mechanics and Maritime Sciences, Chalmers University of Technology, Gothenburg, Sweden. Corresponding author: michele.maglio@chalmers.se

High dynamic wheel–rail contact loads generated by irregularities in wheel/rail surfaces and/or track geometry result in higher fatigue impact on the wheelset. This can lead to a higher rate of wheelset deterioration, increased maintenance costs, and potentially safety related failures.

In order to optimise maintenance intervals without negatively affecting safety, more knowledge regarding the occurrence of high wheelset stresses in operations is needed. Load spectra of a wheelset axle have been gathered using the instrumented telemetry system described by Maglio et al. in [1]. The system was installed on a powered wheelset located at one end of an X40 Swedish regional train. Based on these measurements, the occurrence of operational axle stresses for different stretches has been modelled using statistical distributions. These distributions have been investigated to relate variations in measured stresses to the operational conditions on different stretches (e.g. variations in train speed, track curvature, switches and crossings, wheel and rail surface damage etc.).

By employing these synthesized load spectra, operational loads for wheelsets on specific sections of a network can be estimated from track geometry, maintenance status etc. of the track section. Vice versa, the track status can be deduced from the evaluated load spectrum. This flexible and rapid method would aid operators and infrastructure managers to keep control on the status of their assets and increase operational reliability.

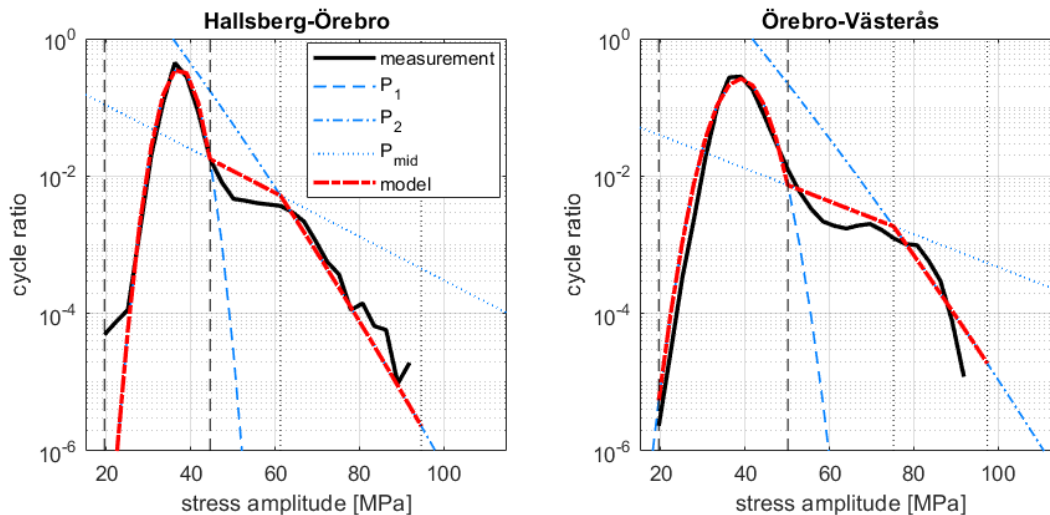

Figure 1. Stress spectra for two track sections. Solid black lines are stress amplitudes obtained from telemetry systems. Dashed red lines are stress amplitudes obtained from fitted probability distributions P_1 , P_2 and P_{mid} .

References

Maglio M, Vernersson T, Nielsen J C O, Pieringer A, Söderström P, Regazzi D, Cervello S. Railway wheel tread damage and axle bending stress – Instrumented wheelset measurements and numerical simulations. *International Journal of Rail Transportation*, 23 pp, 2021.

Probability of rail break due to wheel–rail impact loads

Jens Nielsen, Thomas Abrahamsson and Anders Ekberg

CHARMEC - Department of Mechanics and Maritime Sciences,
Chalmers University of Technology, Gothenburg, Sweden. jens.nielsen@chalmers.se

Wheel–rail impact loads due to discrete irregularities on the wheel tread may lead to severe damage of track and vehicle components. In particular, in case a severely damaged wheel strikes near a pre-existing crack in the rail, the generated impact load may lead to an instant rail break.

In this study, the probability of a rail break (full fracture of the rail), considering a measured distribution of wheel–rail impact loads, is calculated using statistical methods. Based on histograms of dynamic wheel loads measured in wayside detectors on Malmbanan, and a mapping procedure approximating the relation between the dynamic load and the corresponding depth of a given type of tread damage, a three-parameter probability distribution is determined to describe the distribution of tread damage depths. Further stochastic variables θ_i , $i=1, 2, \dots, N$, accounted for in the analysis may for example include rail fracture toughness, initial crack length and impact position of the wheel tread damage relative to the crack position.

A fracture mechanics approach is employed to determine the stress intensity for rail cracks subjected to combined bending and temperature loading. For a given crack length and rail geometry, the stress intensity is influenced by the temperature (relative to the stress-free temperature) and the dynamic bending moment in the rail as induced by the impact load. The dynamic bending moment in the rail is calculated using a model for simulation of vertical dynamic vehicle–track interaction between a heavy-haul car bogie and the track.

A performance function $g(\boldsymbol{\theta})$ is derived accounting for the fracture toughness of the rail and the stress intensity at the crack. The probability of a rail break is determined by the probability that the stochastic parameters are in states such that $g < 0$. The calculation of the probability of a rail break, considering the stochastic distributions of input data, comes at a high computational cost. The reason is the rare occasion of failure events. Here, a meta-model technique is applied to replace the original numerical simulation of the performance function by a surrogate model. Then, the Subset Simulation (SS) algorithm is used to calculate the probability of a rail break.

References

- Nielsen JCO, Abrahamsson TJS, Ekberg A. Probability of instant rail break induced by wheel–rail impact loading using field test data. *International Journal of Rail Transportation* 10(1), 1–23, 2022.
- Ekberg A, Kabo E, Nielsen JCO. Allowable wheel loads, crack sizes and inspection intervals to prevent rail breaks. *Proceedings of the 11th International Heavy Haul Conference*, Perth, Australia, June 2015, 9 p.
- Au S-K, Beck JL. Estimation of small failure probabilities in high dimensions by subset simulation. *Probabilistic Engineering Mechanics* 16, 263–277, 2001.

Using wheel measurements in lifecycle management

Otto Sormunen¹, Curtis Wood¹ and Sami Kalevirta¹

¹ Digital Services, VR FleetCare, Helsinki. firstname.lastname@vr.fi

Introduction

Wheels are a major running cost in train operations. Besides wheel diameter, the wheel profile must also be maintained within specific tolerances especially for high-speed trains. This is done by lathing and replacing wheelsets. The traditional approach is fixed time- or kilometre-based service intervals, which may lead to over-servicing wheelsets thus increasing costs. We present methods that can be used to minimize service costs with condition-based maintenance of wheels.

Wheel-condition monitoring

VR FleetCare owns a laser measurement station in Helsinki, see Figure 1, where wheel profiles are measured with a WheelView device by Trimble/BeenaVision. Calculations are made of various wheel metrics such as conicity. The in-built estimation equivalent conicity is not used – rather an in-house solution, using latest wheel diameter, increased accuracy allowing for an increase of 20% in Sr2 locomotive wheels' life-span and cutting wheel running costs by 17%.

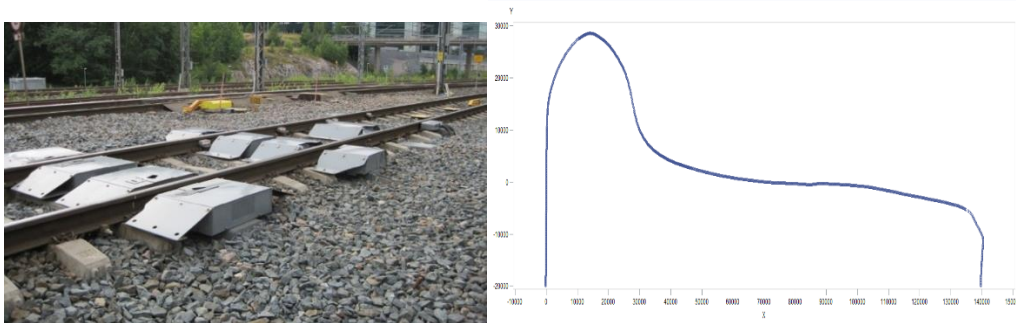

Figure 7. Measurement station (left) and its corresponding wheel-profile measurement (right).

Complementing the laser measurement station, various other sources are used in wheelset-condition monitoring and lifecycle optimization. For example, wheel-bearing temperature and wheel-force measurements are used (from the Finnish Transport Infrastructure Agency: Vöylävirasto) – which can detect defects in wheel bearings or wheels such as flats/spalling – that can then be corrected such as by lathing before the defect escalates or damages other parts or even the tracks. Furthermore, some rolling-stock bogies are being equipped with accelerometers to monitor the bearings, wheels and as bogies themselves. Finally, the effect of wheel profile on service life is investigated.

Conclusions

We present and analyse various wheel measurements in-situ to avoid over-servicing wheelsets as well as to detect wheelsets with defects early that can then be repaired before more damage is done to the train or track.

Rail surface treatment - grinding vs milling in terms of equivalent conicity

M. Asplund¹, I. Persson², J. Wingren³, P. Söderström⁴, B. Dirks⁵, M. Li⁶, LO. Jönsson⁷, A. Qazizadeh⁸ and M. Berg⁹

¹ Maintenance & Environmental, Trafikverket, Luleå, Sweden. matthias.asplund@trafikverket.se

² AB DEsolver, Östersund, Sweden. ingemar.persson@desolver.se

³ Mechanical System, SJ AB, Stockholm, Sweden. jakob.wingren@sj.se

⁴ Mechanical System, SJ AB, Stockholm, Sweden. par.soderstrom@sj.se

⁵ Maintenance & Environmental, Trafikverket, Stockholm, Sweden. babette.dirks@trafikverket.se

⁶ Maintenance & Environmental, Trafikverket, Göteborg, Sweden. martin.li@trafikverket.se

⁷ Analytical Dynamics, Södra Sandby, Sweden. lars-ove.jonsson@anadyn.se

⁸ Rail Vehicles, KTH, Stockholm, Sweden. alirezaq@kth.se

⁹ Rail Vehicles, KTH, Stockholm, Sweden. mabe@kth.se

Introduction

Rails degrade during operation by material removal of the rail surfaces and by crack propagation in the material. To keep the right profile of the rails and to remove the cracks from the railhead, surface treatment is needed. The rail surface treatment is an important maintenance action to prolong the life of rails and preserve the safety on track. The rail treatment is a high-cost maintenance activity and needs to be accomplished optimally, not to increase the cost of the maintenance and not to decrease the safety, and to keep the expected performance of the track.

Different rail treatment technologies give different rail profiles that in turn affect vehicle ride comfort (Jönsson 2017). This presentation investigates how different rail profiles, wheel profiles and treatment technologies influence on the Equivalent Conicity (EC).

Rail treatments

Rail treatments or machining of rails can be performed by grinding or by milling. The most frequent method is rail grinding, but milling is also getting more and more common. Most infrastructure managers have both technologies available and the choice of the technology used depends on e.g. the availability of machines, the time slot on track and how much material needs to be removed. However, the infrastructure managers need also to look on what treatment is the most efficient in the long run for the specific conditions.

Conclusions

Different target profiles (60E1:30 and 60E2:40) influence the EC. The ground rail profile gives, with the nominal wheel profile (S1002), a lower EC than the milled rail profile. Nevertheless, the running distance of the wheel (vehicle) has a higher effect on the EC. In addition, the type of vehicle gives different development of the EC.

References

Jönsson, LO., Asplund, M., Li, M., Söderström, P., "Vehicle vibrations at the Hallandsås tunnel: collaborative investigation and results", Brisbane, 25th IAVSD Symposium on Dynamics of Vehicles on Roads and Tracks, 2017

Evaluation of long-term maintenance of switches & crossings with respect to life-cycle costs and socio-economic impact

Ait-Ali A.¹, Pålsson B.², Odolinski K.³, and Torstensson P.T.⁴

¹ Department of Transport Economics, The Swedish National Road and Transport Research Institute (VTI), Stockholm, Sweden. abderrahman.ait.ali@vti.se

² Department of Mechanics and Maritime Sciences/CHARMEC, Chalmers University of Technology, Gothenburg, Sweden. bjorn.palsson@chalmers.se

³ Department of Transport Economics, The Swedish National Road and Transport Research Institute (VTI), Stockholm, Sweden. kristofer.odolinski@vti.se

⁴ Department of Environment, The Swedish National Road and Transport Research Institute (VTI), Stockholm, Sweden. peter.torstensson@vti.se

Introduction

Switches & crossings (S&Cs) are vital assets as they allow for increased railway capacity by introducing flexibility and connectivity in railway networks. At the same time this makes them critical, and they can cause major delays and disruptions if they are not well maintained. This motivates studies to improve maintenance strategies of S&Cs, considering both life-cycle costs (LCC) of the assets and other additional socio-economic costs (e.g., transportation costs for passengers and freight customers). In this paper, the interdependence between deterioration mechanisms, maintenance activities, and expected LCC (including transportation costs) is investigated using a combination of mechanical and econometric modelling.

Analysis

The interrelation between the degradation of contact geometry and track settlement is analysed using simulations of dynamic vehicle–turnout interaction. Changes in the timing of the associated maintenance measures (crossing repair welding and tamping) are performed to investigate the impact on damage modes. This is then linked to LCC and transportation costs, which requires a distribution between preventive and corrective activities with respect to the simulated maintenance strategy. This relationship is investigated by means of regression modelling:

$$\mathit{Corrective} = f(\mathit{Preventive}, X) \quad (1)$$

where *Corrective* and *Preventive* represent the number of failures and the scheduled actions to prevent these failures, respectively. *X* holds variables related to the traffic (volume, type of traffic, axle load, etc.) and the infrastructure (type of S&Cs, etc.).

Conclusions

The impact of different maintenance strategies, including the relationship between preventive and corrective measures is analysed based on a case study that includes the most common types of S&Cs in Trafikverket's network. Challenges in the development of socio-economically effective maintenance strategies of switches & crossings are discussed.

Ballast condition assessment via tamping machine measurements

Stefan Offenbacher¹

¹ Institute of Railway Engineering and Transport Economy, Graz University of Technology, Graz, Austria.
stefan.offenbacher@tugraz.at

Introduction

Railway ballast and track tamping are two interrelated topics which significantly affect the quality and longevity of ballast tracks. The ballast transfers train-induced forces from the sleepers to the substructure and secures the track panel in its position. Consequently, the track bed significantly defines the track geometry and determines the need for tamping operations. Due to varying properties of track ballast its general condition is difficult to assess. This also complicates tamping machine operation which requires applying optimal machine settings at any track condition. The presented research project aims at addressing both issues.

Methodology and results

Austrian manufacturer Plasser & Theurer have equipped the tamping tools of a universal tamping machine with a sophisticated sensor setup (Figure 10Figure 10). Combining these sensor measurements (e.g. horizontal forces in the tamping tines during the ballast squeezing movement; Figure 10b) with recordings of applied machine settings allows for a holistic view and detailed investigation of the tamping process. Conventional information on the track sections where the tamping machine operates (mainly in the networks of OeBB and SBB) serves as reference to contextualize the tamping machine measurements. This information includes track data, fractal analyses of the track geometry, or laboratory analyses of ballast samples. Various evaluations of this ongoing research project highlight the potential of the methodology; Figure 10c exemplarily shows the effect of the ballast condition on the measured penetration force. The tamping data will deliver valuable information to infrastructure managers without separate inspections. The data can also be supplied to the tamping machine operator in real-time, thus facilitating optimal machine parameter adjustments depending on the prevailing ballast condition.

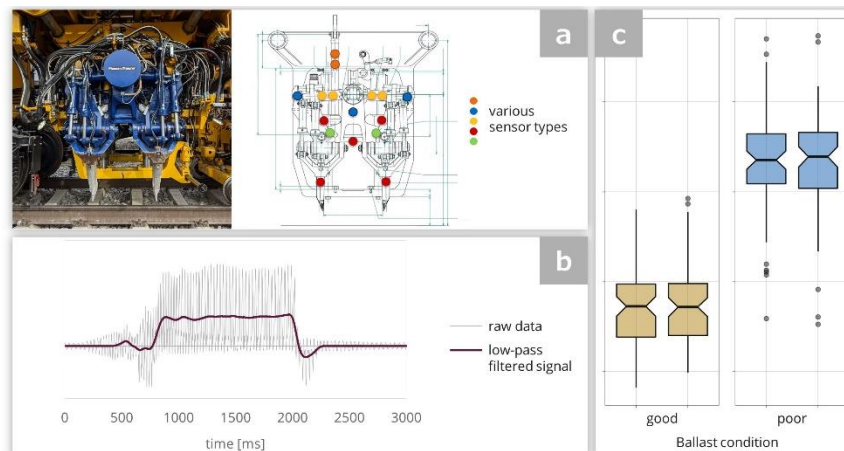

Figure 1. (a) Sensor setup, (b) measurement data and (c) exemplary results of the research.

Instructions on Design and Implementation of Tamping on Finnish State Rail Network

Anton Aronen¹ and Henri Seppälä²

¹ Railway Design, Finnish Transport Infrastructure Agency, Helsinki, Finland. anton.aronen@ftia.fi

² Railway Technology, Finnish Transport Infrastructure Agency, Oulu, Finland. henri.seppala@ftia.fi

Introduction

The Finnish Transport and Communications Agency (Traficom) stated in the early 2010s that to ensure railway safety on Finnish state rail network, instructions are needed for tamping. The instructions were written in cooperation with The Finnish Transport Infrastructure Agency (FTIA) and Sweco Infra & Rail (known before as NRC co). The instructions were first published in June 2018 and updated in 2019 and 2021 based on feedbacks gathered from users of the instructions.

Analysis

The actual tamping process where the ballasted track is lifted, lined and tamped to achieve the designed track geometry is just the tip of the iceberg when all the vital preparations and finishing works are considered. The Tamping Instructions gather all essential working stages from pre-measuring for tamping to refurbishing the superstructure to ensure successful tamping.

Conclusions

The tamping process involves many branches of the railway system, consisting of stages like superstructure refurbishing, track geometry measurements, turnout inspections, signalling, overhead line adjustment etc. The main message of the instructions is to have all experts from different technology areas designing and implementing the tamping process in cooperation to ensure high-quality tamping.



Figure 1. Cover page of the tamping instruction.

References

Tukemistyön suunnittelu ja toteuttaminen, Väyläviraston ohjeita 31/2021.

Long Term Effects of Reduced Track Tamping Works

S. Marschnig¹, M. Fellinger¹ and J. Neuhold¹

¹ Institute of Railway Engineering and Transport Economy, Graz University of Technology, Graz, Austria.

stefan.marschnig@tugraz.at

Introduction

Tamping needs to guarantee safety in limiting geometric failures in isolated points, reduce dynamic forces by a smooth through-going longitudinal level, and provide a certain riding comfort for passengers. Although different methods are applied to describe geometry deterioration, the amount of tamping needed is seldomly addressed. Maintenance planning, especially the planning of railway track tamping, is mostly limit value driven and thus concentrates on repairing failures rather than keeping the track at a sustainable quality level.

Methodology, analysis and results

In this work, we evaluated and compared different tamping regimes and their long-term consequences by extrapolating the longitudinal level of track. Forecasting beyond one tamping action needs a precise positioning of measurement data and a solid methodology. We found that tracks can be operated by repairing isolated defects for more than ten years without running into technical and operational trouble, and even reducing budgets in this period. However, the long-term perspective financially shows the contrary: continuous through-going maintenance keeps track quality at a high level and provides the basis for a long service life.

The procedure published in this paper can be easily applied by railway infrastructure managers in order to ensure a high-quality infrastructure and to guarantee sufficient budgets.

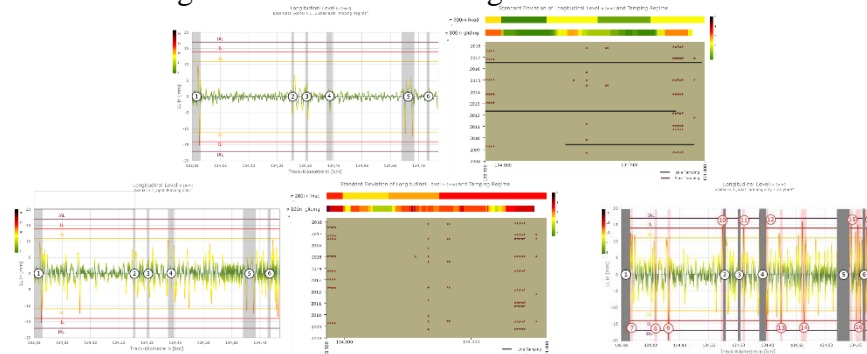

Figure 1. Development of Track Quality for different Tamping Regimes.

References

- Neuhold, J.; Vidovic, I.; Marschnig, S. Preparing Track Geometry Data for Automated Maintenance Planning. *J. Transp. Eng. Part A: Syst.* 2020, 146, 04020032.
- Fellinger, M.; Neuhold, J.; Marschnig, S. Ballast Condition Monitoring for Turnouts Using Power Spectral Density. *J. Transp. Eng. A* 2020, 146, 04020099.
- Neuhold, J. Tamping within Sustainable Track Asset Management; Monographic Series TU Graz / Railway Research, vol. 6; Ver-lag der TU Graz (Graz, Austria), 2020, ISBN: 978-3-85125-782-3, 228.

Prediction of differential track settlement in transition zones using a non-linear track model

Kourosch Nasrollahi¹, Jens C. O. Nielsen¹, Jelke Dijkstra², and Magnus Ekh³

¹ Department of Mechanics and Maritime Sciences, ² Department of Architecture and Civil Engineering, ³ Department of Industrial and Material Science,
Chalmers University of Technology, SE-412 96, Gothenburg, Sweden.
kourosch@chalmers.se

In transition zones between two different railway track forms, there is a discontinuity in track structure leading to a gradient in track stiffness. Examples include transitions between different superstructures, e.g., slab track to ballasted track, and/or between different substructures, e.g., embankment to a bridge or tunnel structure. Differences in loading and support conditions at the interfaces between track superstructure and substructure on either side of the transition may lead to differential track settlement and an irregularity in longitudinal rail level soon after construction because of consolidation and densification of ballast and soil. This results in an amplification of the dynamic traffic loading along the transition, contributing to the degradation process of the foundation and resulting in a further deterioration of vertical track geometry.

In this study, an iterative procedure for the prediction of differential track settlement in a transition zone between 3MB slab track and ballasted track is presented. The track model is a non-linear finite element model accounting for gravity load, state-dependent foundation stiffness and hanging sleepers, while the empirical settlement equation is based on similar ideas as for a visco-plastic material mechanics model. To demonstrate the procedure, the influence of axle load in heavy haul traffic on dynamic loads and long-term settlement in a transition between ballasted track and slab track is investigated.

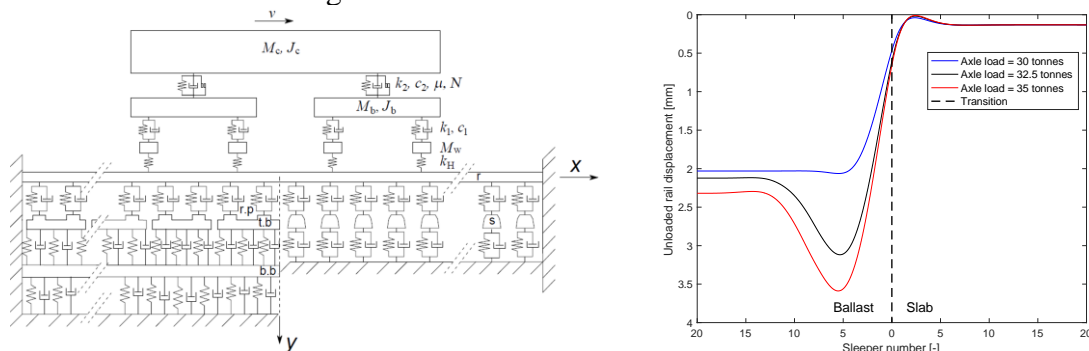

Figure 1. (left) Vehicle and track models used in the simulation of dynamic vehicle-track interaction at a transition. (right) Example illustrating the predicted influence of axle load on rail displacement due to gravity load (longitudinal level) after an accumulated traffic load of 50 MGT. Train speed 60 km/h. Results for 2 mm initial vertical misalignment on ballasted side

References

Nasrollahi, K., J.C.O. Nielsen, E. Aggestam, J. Dijkstra, and M. Ekh. 2021. "Prediction of differential track settlement in transition zones using a non-linear track model." To appear in the proceedings of the 27th IAVSD Symposium on Dynamics of Vehicles on Roads and Tracks, St Petersburg (Russia) August 2021, online conference.

Train load effect on a buried structure

Panu Tolla¹ and Kim Andersson-Berlin²

¹FTIA, Helsinki, Finland

²Profund Ltd, Turku, Finland

Abstract

Profund Ltd and FTIA have carried out a study to evaluate train load vertical and horizontal effects on buried structures, such as pile supporting embankment slab. Plaxis 3D FEM software was applied to model the static impact of axle loads on underground structures. In the first stage, a pile supported embankment slab was studied alone and in the second stage a complete model of a bridge between pile supported slabs were analyzed.

The train load was applied in accordance with the dimensions of the axle loads in LM-71 with some modification: the uniform load component was displaced by multiple axle groups. The distance between the axle groups correspond to 80 kN/m. Horizontal component is set as 25% of the vertical load as ultimate breaking force in accordance EN1991-2. The selected train load was based on load effect analyses in previous studies.

In the first model, the load distribution has been investigated on a 20 m long piled slab of prefabricated elements that is 1.5 m below the rails. The slab is inside the embankment fill, which lies on soft clay. In the modeling, it is assumed that voids are formed under the piled slab. The element plate has been modeled with elements that lay on three piles each. The elements are attached with steel brackets. The prefabricated elements stand on two rows of piles that can be installed before removing the existing track. The slab elements bend in the middle under load, which is developed arching effect in the railway embankment.

The slab length is very short when it is compared the load from a braking train. The most important results of the modeling are that the horizontal load resistance of a piled slab on vertical piles is determined by the vertical stiffness of the ground. The piled slab is horizontally slightly stiffer than the surrounding railway embankment, because part of the horizontal load is carried via resistance the piles at the bottom of model piles. The proportion depends on the length of the piles. It is smaller the longer the piles are. A piled slab is based on only vertical piles thus moves horizontally in accordance with the surrounding railway embankment.

In the second stage, the model has been investigated with a bridge that is extended with piled slabs on both ends of the bridge. The bridge has ballasted track on the deck. The railway embankment is modeled on surround ground surface level and it carries a three meters high railway embankment. Both the bridge and the piled slabs are founded on vertical piles. Also in this model, the piles of the piled slabs are in two rows, one on each side of the track. In the calculations, the effects of train load on the various surfaces of slabs and the bridges have been investigated. The results show that the bridge is less rigid in the horizontal direction than the railway embankment. The train vertical and horizontal load effected on various locations on the structures or close to them. The horizontal support of the bridge is based on the ground pressure against the end beams and it was found the supporting ground pressure due to the earth's own weight in short bridges is significantly greater than the horizontal component of the train load. The movements calculated in these modeling are very small.

The results of this study form a base to revise train load model for buried structures, such as piled embankment slabs, in FTIA specification. The LM71 model was found to be unsafe side due to combination of axle loads and uniform (infinite) load. The horizontal load effects dependency of structure stiffness was studied. The study provides basis to revise FTIA specification from that perspective. The results are published in details in FTIA report: <https://urn.fi/URN:ISBN:978-952-317-939-4>

Modeling the loading behavior of railway structure

Marko Peltomäki¹, Heikki Luomala² and Pauli Kolisoja³

¹ Research Centre Terra, Tampere University, Tampere, Finland, marko.peltomaki@tuni.fi

² Research Centre Terra, Tampere University, Tampere, Finland, heikki.luomala@tuni.fi

³ Research Centre Terra, Tampere University, Tampere, Finland, pauli.kolisoja@tuni.fi

Abstract

When trying to optimize the life-cycle behavior of railway structures it is important to identify the main deformation factors of the structure and to understand the influence mechanisms behind these. Due to the complex behavior of railway structures, powerful numerical tools are needed to get realistic simulation results. Therefore, the focus of this study has been to create a three-dimensional finite element model to simulate the loading behavior of different railway structures under various axel load levels. The model is verified using measured field data from heavily instrumented test structures. The calculations mainly focus on the behavior of railway embankments of different subgrade stiffness and granular layer thickness. It is shown that subgrade stiffness seems to have a major role on the behavior of railway structures, whereas the influence of the axel load seems to be fairly linear.

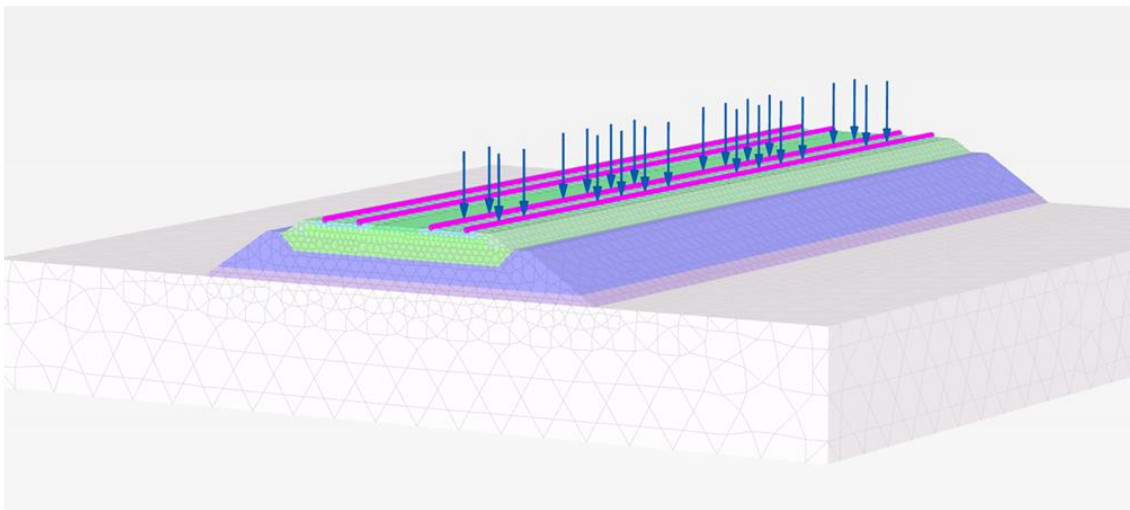

Figure 8. Picture of one FE-model used for the verification

Improved modelling of tread braked wheels using an advanced material model and brake rig test

Eric Voortman Landström, Tore Vernersson and Roger Lundén

Department of Mechanics and Maritime Sciences/CHARMEC, Chalmers University of Technology, Gothenburg, Sweden, ericlan@chalmers.se

Railway freight wagons are often braked using mechanical friction brakes in the form of tread brakes that act directly on the tread of the wheels which at the same time are in rolling contact with the rail. The tread brakes should provide sufficient braking capacity of the train for both normal service braking and extreme braking conditions. This braking system requires a minimum of components and is therefore a low-cost and low-maintenance choice for the industry. However, the utilisation of the wheel as a friction-heated component, also worn by the brake, comes at a cost in form of complex loading situations in which elevated temperatures resulting from braking are interacting with the wheel-rail rolling contact loads. In order to safely employ the brakes in all situations, accurate knowledge about how the materials interact during these loading situations is required. Studies have shown that temperatures above 500 °C are to be expected, and cases with temperatures in excess of 600 °C may occur. At such high temperatures, the normally employed ER7 wheel steel is significantly weakened and shows sign of rapid material breakdown by, e.g. spheroidization of the pearlitic material structure. To account for these effects, computational models capable of simulation of the complex thermomechanical behaviour are a must. As part of our recent research, a novel viscoplastic material model has been calibrated against isothermal low cycle fatigue tests and also against thermomechanical experiments based upon actual in-service scenarios for a range of temperatures, showing good results for wheel material. The novel material model constitutes a further enhancement of previously developed models that were calibrated solely by use of isothermal materials testing.

The objective of the present study is to further investigate and examine the capabilities and accuracy of the novel material model when employed in detailed braking simulation. To achieve this, a FE model of a standard freight wheel during tread braking is used to assess the performance of the material model. The finite element model accounts, in a simplified fashion, for residual stresses introduced by the rim hardening process at wheel manufacturing and also for variations in material properties based on typical hardness values on a wheel cross section. A range of braking situations are assessed to achieve different conditions, mainly by mimicking downhill braking at constant speed for a prolonged time period.

The numerical results are then compared with the pertinent European standard on technical approval for forged wheels and previous material models calibrated only for isothermal data. In addition to this, the thermomechanically calibrated model results are also compared to experimental results, including circumferential residual stresses in the wheel rim as well as rim deflections, gathered using a new full-scale brake test rig at Chalmers.

The results show that the material model predicts realistic material behaviour for a wide range of braking situations. Compared with previous models, a general improvement is seen, suggesting that the newer features of the material model contribute substantially to more accurate modelling of the processes occurring in the wheel during high temperature tread braking.

Tread braking and winter conditions

Tore Vernersson¹ and Roger Lundén¹

¹ CHARMEC - Department of Mechanics and Maritime Sciences, Chalmers University of Technology, Gothenburg, Sweden. tore.vernersson@chalmers.se

Tread braking is a common braking system on railway vehicles and is the dominating system for freight wagons. Brake blocks can be made from cast iron, organic composite or sinter materials. Traditionally, cast iron brake blocks have been used and the railway industry has adapted to their specific braking performance. However, because of the excessive rolling noise levels, which are caused by high wheel roughness introduced at braking with the cast iron blocks, there is today a shift away from these blocks. This is propelled by societal demands being enforced by legislation on EU level, but also by some influential countries. To this end, a novel type of brake blocks, so-called LL brake blocks, constitute a retrofit solution with organic composite or sinter blocks replacing the cast iron brake blocks.

During the last few years it has been observed in the Nordic countries (Finland, Norway and Sweden) that the LL type brake blocks exhibit problems in their braking performance at some specific winter conditions. This constitutes a safety problem and has caught the attention of freight operators, wagon owners and also the Swedish Transport Agency (Transportstyrelsen). For this reason, test campaigns have been performed both in Finland (by VR) and in Sweden (by Transportstyrelsen). During the winters 2019-2020 and 2020-2021, major efforts were made in Sweden to provide more information on winter braking performance, overseen by Transportstyrelsen and supported by Trafikverket and Green Cargo. A test train comprising one unbraked locomotive and five test wagons made several daily stop braking cycles between Haparanda and Boden in northern Sweden. The test campaigns had two major aims: 1) Brake distance evaluation to identify unsafe winter braking condition and 2) Friction performance evaluation using a detailed instrumentation to investigate root causes for reduced braking efficiency in winter conditions. At the presentation, results will be provided from the test campaigns with information on differences and similarities between the two types of brake blocks for varying winter conditions.



Figure 1. Example of build-up of ice and snow in bogie during winter conditions

Wear of wheel treads and brake blocks at railway tread braking

Roger Lundén¹, Tore Vernersson¹ and Mandeep Singh Walia²

¹ Chalmers University of Technology / CHARMEC, Gothenburg, Sweden

² Green Cargo, Solna, Sweden

roger.lunden@chalmers.se

Tread brakes are one of the most common braking systems on railway vehicles. They are simple, inexpensive and lightweight and are also easy to install, maintain and replace. Apart from the braking action, they also improve the wheel–rail adhesion by increasing the roughness of the wheel tread and by removing contaminants. Tread braking means that brake blocks are pressed towards the wheel tread to provide the required braking performance. Brake blocks can be made from cast iron, organic composite or sinter materials. However, today there is a shift away from cast iron brake blocks since they at braking cause high wheel roughness which results in excessive rolling noise levels.

Tread braking also introduces wear of wheel treads and brake blocks in the sliding block–wheel contact and of the wheel tread and the rail in the wheel–rail rolling contact. The wear can be related to the frictional energy generated between blocks and wheel and to the frictional energy in the wheel–rail rolling contact. On top of this, the wheel tread is also deformed plastically in the wheel–rail rolling contact, which, especially at elevated temperatures, changes the tread geometry. Wear of the tread braking system has been studied in two papers, see the references below, by use of a combination of field testing, numerical analyses and brake rig testing. These findings, see the example in Figure 1, will be presented and further discussed and some explanatory examples will be given.

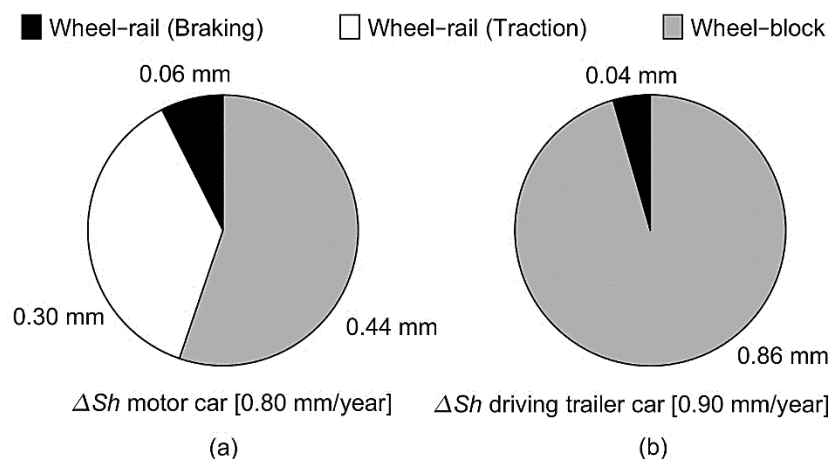

Figure 1. Tread wear from different sources in the form of change of flange height for a powered wheel (left) and for a non-powered one (right)

References

Walia, M. S., Vernersson, T., Lundén, R., Blennow, F. and Meinel, M., “Temperatures and wear at railway tread braking: Field experiments and simulations” *Wear*, 2019, vols 440-441, article 203086, 9 pp

Walia, M. S., Vernersson, T., Handa, K., Ikeuchi K. and Lundén R., “Wear and plastic deformation of the wheel tread at block braking – Results from brake rig experiments and simulations”, Proceedings 19th International Wheelset Congress (IWC 2019), Venice (Italy), 2019, 5 pp

Predicting equivalent conicity by Gradient Index Profile

Ingemar Persson¹ and Lars-Ove Jönsson²

² AB DEsolver, Östersund, Sweden, ingemar.persson@desolver.se

³ Analytical Dynamics AB, Lund, Sweden, lars-ove.jonsson@anadyn.se

To give a good ride comfort the equivalent conicity shall be not too high and not too low. If the conicity is too high the vehicle may suffer from bogie instability. If the conicity is too low the vehicle may suffer from carbody instability.

Therefore, it is important to keep the wheel and rail profiles within certain limits, to avoid wear and instability problems. Infrastructure managers often compare their measured rail profiles with theoretical new wheel profiles, and train operators compare measured wheel profiles with theoretical rail profiles. If the equivalent conicity is calculated of a measured rail profile against a new ideal wheel profile, or a measured wheel profile is calculated against a new rail profile, both results may show satisfactory results, whereas the true combination can give an unacceptable equivalent conicity. The calculation of equivalent conicity is compute intensive and needs to be repeated for each different wheel profile.

The Gradient Index Profile, or GIP for short, was introduced [1] to handle these issues. The GIP is calculated by comparing the gradient (inclination) of the wheel profile at the running circle with the corresponding gradient of the rail profile. The predictive power of GIP will be discussed. An example is shown below, where GIP and equivalent conicity are calculated for 2x65 (left/right) wheel profiles combined with 2x492 rail profiles. Limit values of conicity (0.25) and GIP (-0.116) are indicated in the figure. In 91% of the cases the correct high or low conicity is predicted by GIP. Only 1.3% are wrongly predicted as low conicity.

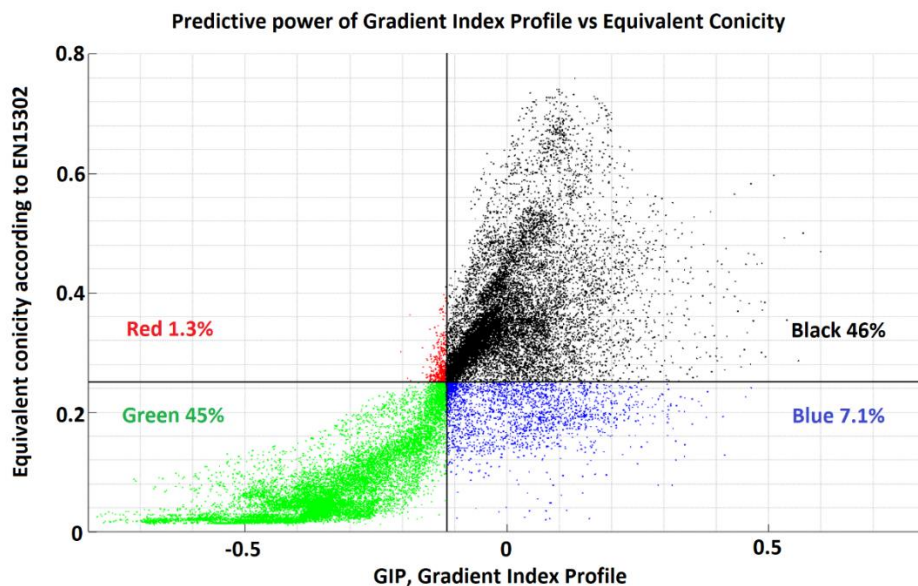

References

- [1] Persson, Ingemar and Jönsson, Lars-Ove. "Gradient Index Profile, a novel idea for predicting equivalent conicity". Proceedings of the IAVSD 2021 Symposium, to be published.

Estimation of traction at high creepages and its application to prediction of wear, RCF and squeal noise

Elham Khoramzad¹, Saeed H-Nia¹, Carlos Casanueva¹, Mats Berg¹

¹ Engineering Mechanics, KTH Royal Institute of Technology, Stockholm, Stockholm. elhamk@kth.se

Introduction

In many applications of railway track and vehicle analysis, such as wheel-rail damage and squeal noise, an accurate solution for the wheel-rail contact problem is necessary. In this study, shear stress distribution over contact area is calculated using FaStrip [1] algorithm and impact of slip velocity on the coefficient of friction used in this algorithm is modelled by concept of “friction memory” [2]. Resulting shear stresses are then used to estimate wear, rolling contact fatigue (RCF) and predict generation of squeal noise.

Analysis

The friction coefficient at contact patch is not constant but a function of the slip velocity. As wheel starts to slip on rail, the friction coefficient starts to decrease, leading to further increase of slip velocity and consequently more decrease of friction. This falling friction affects shear stresses over the contact area. Figure 2 illustrates the shear stress distribution over the contact patch for three different contact models considering falling friction.

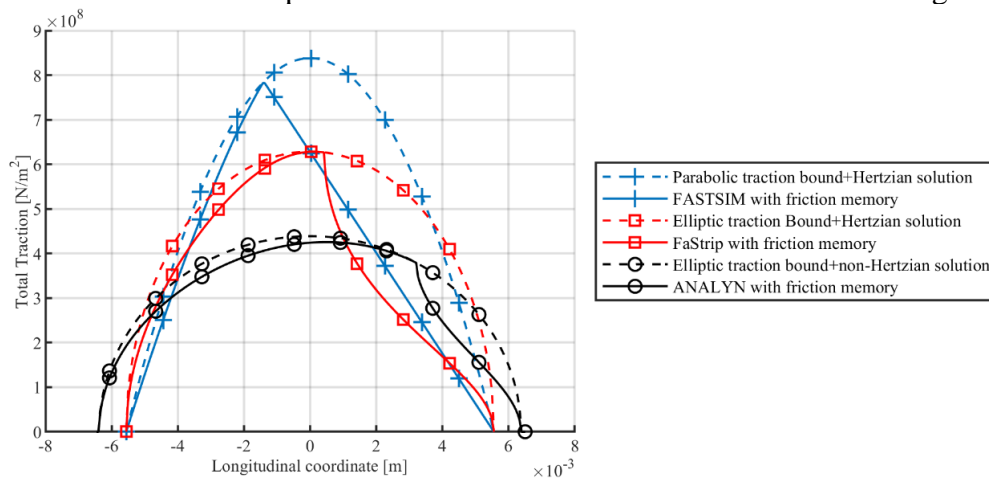

Figure 1. Traction distribution over contact area for three different contact models.

Conclusions

Estimation of wear, (RCF) and squeal noise occurrence are influenced by the changes of stress distribution on contact area due to falling friction. Therefore, it can be valuable to implement these estimations in maintenance planning to minimize the costs and traffic interruptions.

References

- [1] Sichani MSh., Enblom R., Berg M., (2016). "An alternative to FASTSIM for tangential solution of the wheel-rail contact". *Journal of Vehicle System Dynamics*.
- [2] Vollebregt E.A.H. (2015) "FASTSIM with Falling Friction and Friction Memory." *Notes on Numerical Fluid Mechanics and Multidisciplinary Design*.

Track-friendliness of freight wagons on the Finnish Rail Network

Muhammad Rizwanullah Shaik¹

¹TerraRail, Tampere University, Finland. rizwanullah.shaik@tuni.fi

Abstract

The study of track-friendliness of freight bogies has been essential over the years, with increasing demands for higher tonnage, operating speeds, and minimal impact on the track. A vast majority of the freight wagon fleet in Europe still runs with the classic bogies – the Y25s, the 18-100s, Link bogies, etc. The Finnish rail network has many operators that use these types of bogies, whose loading effects are not known.

The principal aim of this research is to understand the loading behaviour of the freight wagons running on different sections of the line in Finland. An extensive review is carried out to study the design differences of the equipment; effect of the sprung and unsprung masses; role of primary and secondary suspension; clearances in the lateral, longitudinal and vertical direction; and the steering ability in curved sections.

A road map is then developed to determine how the track-friendliness of different bogies could be estimated. Different parameters like forces, track irregularities, stiffnesses, as well as situations like the vehicle running speed, curve radius, cant deficiency are categorized accordingly that show differences in the dynamic performance of these bogies. MBS simulations are also developed simultaneously taking into consideration these categorized situations. In the end, a framework is developed that helps in the assessment of track-friendliness of the different freight bogies.



Figure 1. Typical Y25 freight bogie with coiled spring primary suspension and a lenoir link.

Keywords

Bogie frame, Friction damping, track irregularities, radial steering, hunting, wear

The effect of water content on permanent deformations in railway structure

Juha Latvala

Research Center Terra, Tampere University, Finland. juha.latvala@tuni.fi

Introduction

Water content is one of the most important factors influencing the performance of earth structures. According to Li and Selig (1995), cyclic loading and fine-grained materials with excessive water content establish a poor combination in terms of track geometry stability. As a result of climate change, the floods and heavy rainfalls are predicted to increase. These factors have led to the situation where the Finnish Transport Infrastructure Agency and the Tampere University initiated a research project to investigate the effects of track water content on loading resistance to identify the potential benefits of improved drainage.

Analysis and conclusions

The cyclic triaxial tests were made for four different track substructure materials, three of which were taken from the sub-ballast layer of Finnish track section to analyse the effect of water content. In these tests the large differences between the materials cyclic loading resistance were measured at different water contents. Based on these tests, it can be stated that:

- In all four materials examined, the cyclic loading resistance decreased with increasing water content. The risk of deformation increases significantly if the average grain size and the uniformity coefficient of sub-ballast materials are too small.
- The effect of axle load is important, many materials can work adequately if the axle load is about 160 kN (passenger traffic) but 225 kN axle load starts fully utilizing the strength properties of substructure materials, especially with the low-quality ones.
- It is likely that sites with unevenness problems are multi-problematic and the benefits measurable by improving drainage alone may be small unless the track sub-ballast layer is nearly fully saturated.

More extensive description of the topic is available on open access article “The cyclic loading resistance of old railway track sub-ballast materials at different water contents” by Latvala et al. 2022.

References

Latvala, J., Kolisoja, P., Luomala, H. (2022). The cyclic loading resistance of old railway track sub-ballast materials at different water contents. *Transportation Geotechnics*, vol 35.

Li D, Selig ET.(1995). Evaluation of railway subgrade problems. *Transportation Research Record* 1995;1489:17.

Application of a Robust Photogrammetry Method for Uplift Measurements of Railway Catenary Systems in Noisy Backgrounds

Tengjiao Jiang¹, Anders Rønnquist², Gunnstein Thomas Frøseth³

¹ Dep of Structural Engineering, NTNU, Trondheim, Norway. tengjiao.jiang@ntnu.no

² Dep of Structural Engineering, NTNU, Trondheim, Norway. anders.ronnquist@ntnu.no

³ Dep of Structural Engineering, NTNU, Trondheim, Norway. gunnstein.t.froseth@ntnu.no

Introduction

The challenge in measuring the vertical displacement of the railway catenary systems is to detect linear rigid body motion in front of a noisy background, e.g., trees, with a high sampling frequency. A portable vision-based tracking system with a novel line tracking algorithm[1, 2] is used and applied to enable low-cost, remote, non-contact and non-marker uplift measurement of railway catenary wires. The system consists of a high-speed area scan camera (Basler ACA2000-165 μm), a fixed-focal optical lens, a trigger, a laptop and a laser range finder (Leica DISTO™ D8).

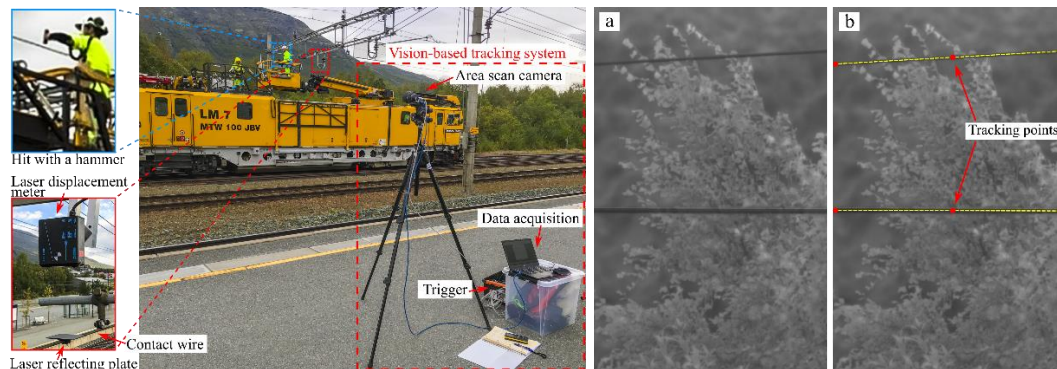

Figure 1. Field uplift measurement of railway catenary wires.

Application of the vision-based tracking system

Field uplift measurement of a railway catenary system was carried out at Oppdal in Norway to test and verify the performance of the proposed vision-based tracking system in an outdoor environment. The accuracy of the tracking algorithm was tested by comparison between laser displacement meter and vision-based tracking system measurements. In the field test, the vision-based tracking system was mounted at a secure distance from the railway as shown in Figure 1. The laser displacement meter (DME ODS200) was mounted on the support structure above the contact wire, in order to have a reference, also shown in Figure 1. The contact wire was fixedly excited by an impulse modal hammer. From the obtained results, it is concluded that the vision-based tracking system can be used for field uplift measurement of railway catenary systems, and offers the attractive advantages of remote, non-contact and non-marker measurement, without track access, and is easy to install and apply.

References

[1] T. Jiang, G.T. Frøseth, A. Rønnquist, E. Fagerholt, A robust line-tracking photogrammetry method for uplift measurements of railway catenary systems in noisy backgrounds, *Mech. Syst. Signal Process.*, 144 (2020) 106888.

[2] T. Jiang, A. Rønnquist, Y. Song, G.T. Frøseth, P. Nåvik, A detailed investigation of uplift and damping of a railway catenary span in traffic using a vision-based line-tracking system, *J. Sound Vib.*, (2022) 116875.

The railway catenary condition monitoring: a systematic mapping

Shaoyao Chen¹, Gunnstein T. Frøseth¹, Stefano Derosa¹, Albert Lau²

1. Department of Structural Engineering, NTNU, Trondheim, Norway
2. Department of Civil and Environmental Engineering, NTNU, Trondheim, Norway
shaoyao.chen@ntnu.no

Introduction

In this work, a systematic mapping of the researches on catenary monitoring in recent five years is presented. The aim of the mapping is to provide a structure of the researches reported in various publications and help the reader to grasp an efficient insight into the general status of those researches.

Analysis

To construct the mapping, the search string is firstly customized, then the searches among mainstream databases are carried out, followed by the screening process (there are 70 publications passing the screening), and in the final step, the mapping is created. In this work, three perspectives are chosen as the dimensions of the mapping, they are monitoring targets, sensors types, and monitoring platforms. For each dimension, the percentages of each sub-type within the dimension are reported in the map.

Conclusions

From the bubble map at the right, it shows that the camera sensor is the most commonly-used sensor type in monitoring researches. And the monitoring focuses on catenary components defects, arc, contact condition monitoring. And it is a trend that those monitoring devices are installed on the train in ordinary service.

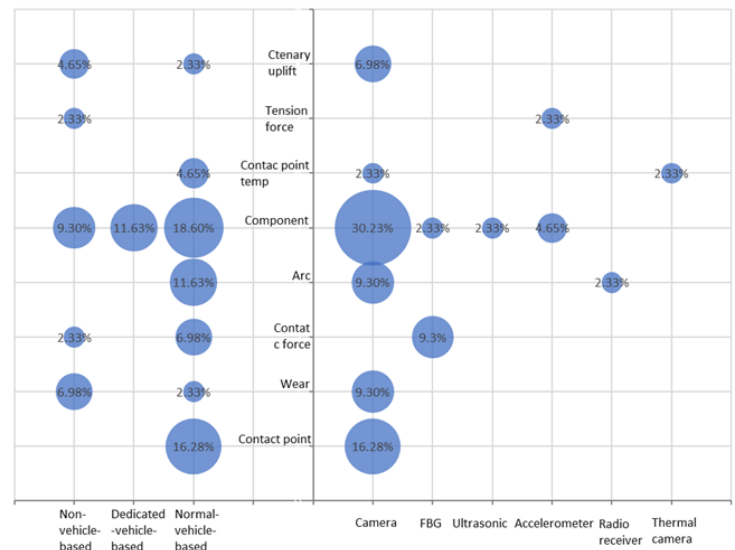

Figure 9. Bubble map of the mapping

References

Labonnote, N., Rønnquist, A., Manum, B., & Rüther, P. (2016). Additive construction: State-of-the-art, challenges and opportunities. *Automation in construction*, 72, 347-366.

The health condition of the catenary system is significant for the smooth operation of the most railway system. The condition monitoring of the catenary system has become a focus in recent years.

Visualising track geometry deterioration modelling

Mikko Sauni¹, Heikki Luomala², Pauli Kolisoja³ and Tapio Nummi⁴

¹⁻³ Built environment, Tampere University, Tampere, Finland. first.last@tuni.fi

⁴ Computing sciences, Tampere University, Tampere, Finland. first.last@tuni.fi

Introduction

Track geometry deterioration modelling provides information on the past, prevailing, and future condition of railway tracks. Different modelling approaches and methods are available for producing pertinent information to railway asset managers. However, modelling results can be complex and difficult to assimilate. Therefore, this study focused on providing insightful visualisation from track geometry deterioration modelling to benefit practitioners.

Analysis

The track geometry deterioration modelling was based on a robust linear optimisation of longitudinal level standard deviation time series data. However, it is considered that the methods presented here are suitable for any track geometry parameter with linear deterioration patterns.

Results and Conclusions

The visualisations cover three scopes of observation: 1) cross section, 2) track section, and 3) network. Visualisations of past, current, and future track geometry behaviour are produced for each scope. The scopes require different visualisations, as the amount of detailed information decreases as the scope is widened. These visualisations present the modelling results in an intuitive way for practitioners to utilise in their daily operations. Thus, the gap between research and practice in deterioration modelling is narrowed.

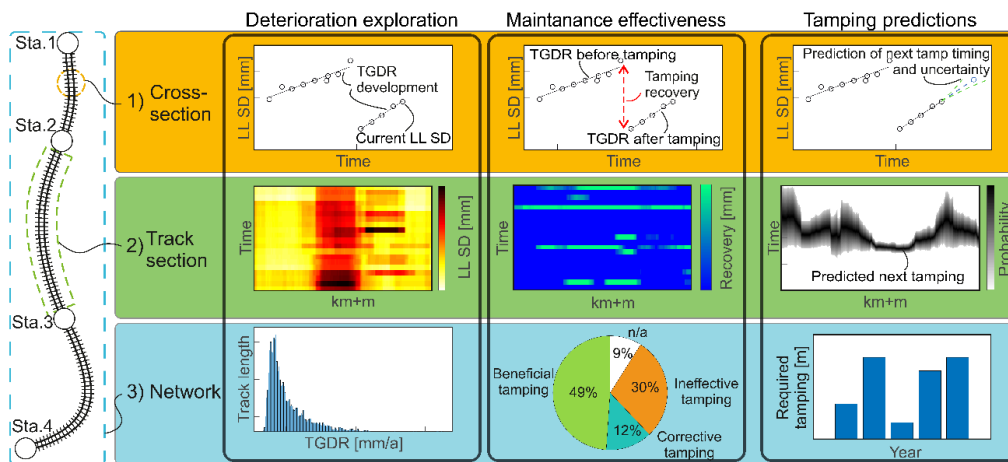

Figure 1. Track geometry deterioration modelling visualisations. (Sauni et al., 2022)

References

Sauni, M., Luomala, H., Kolisoja, P. and Nummi, T. (2022), “Advancing railway asset management using track geometry deterioration modelling visualization”, *Journal of Transportation Engineering, Part A: Systems*, Vol. 148 No. 2, available at: 10.1061/JTEPBS.0000626.

Track geometry quality measurements from working machines

Eric G. Berggren¹, Mikael Pettersson², Mattias Mattsson³ and Björn Skatt³

¹ EBER Dynamics AB, Falun, Sweden. eric.berggren@eberdynamics.se

² MethoTech AB, Köping, Sweden, mikael.pettersson@koping.net

³ Latronix AB, Täby, Sweden. mattias.mattsson@latronix.se

Introduction

According to requirements of Trafikverket (Swedish Transport Administration), measurement of track geometry quality (TGQ) is required after certain track work before traffic is allowed in line speed again. Due to lack of relevant equipment speed restrictions are often needed, causing delays. In order to meet this need, a simplified measurement equipment has been developed that could be mounted on the machine conducting the actual maintenance work. The equipment is based on previous deliveries of TGQ-systems for track recording vehicles in the Nordic countries.

The EN-13848 standard describes requirements for the measurements, both for track recording vehicles (part 2) and working machines (part 3). The new system is designed for measurement speeds from 10 km/h and higher. Lower speeds may be feasible but has not yet been verified.

Results

The measurement equipment was used at Roslagsbanan, a narrow-gauge track for commuting north of Stockholm. During the measurements a reproducibility test according to EN-13848 was executed. The results are found in table 1.

Table 1. Results from reproducibility test.

Parameter	Reproducibility	EN13848-2	EN13848-3
<i>Longitudinal level</i>	0.26 mm	0.8 mm	2 mm
<i>Alignment</i>	0.28 mm	1.1 mm	2 mm
<i>Track gauge</i>	0.26 mm	1 mm	1 mm
<i>Twist</i>	0.08 / 0.04 mm	0.5 mm	0.42 mm
<i>Cross-level</i>	0.51 mm	2.5 mm	2.5 mm

Even though the system is simplified and designed for lower cost and rough environment, the measurement uncertainty is well below the requirements of EN13848 (95 % of all measurements have lower uncertainty than the figures of table 1).

References

EN 13848 – Railway applications – Track – Track geometry quality.

Part 1. Characterisation of track geometry,

Part 2. Measuring devices – Track recording vehicles

Part 3. Measuring devices – Track construction and maintenance machines

A study on the use of Short-Time Fourier Transform (STFT) analysis for track geometry evaluations concerning cyclic irregularities

Martin Li

Uhtsp1, Trafikverket, SE-411 04, Göteborg, Sweden. martin.li@trafikverket.se

Abstract

Following the requirements of European railway interoperability, TSI INF, as well as the European standard in the series of SS-EN13848, primary track geometric parameters, i.e. longitudinal level, alignment, track gauge, cross level and twist, are routinely measured and used by infrastructure managers (e.g. Trafikverket) for safety control and maintenance planning. However, under certain circumstances, for example, when cyclic track irregularities occur, the standard methodologies according to SS-EN13848 are not sufficient.

A cyclic track irregularity is identified when one of the primary track geometric parameter shows a periodical characteristic, meaning that local maxima are repeated with a fixed wavelength. Even if each peak value is not big, the repetitive nature with a fixed wavelength may trigger a resonance of the suspension system of a vehicle. Consequently, the risk for unstable running behaviour will be high and may eventually lead to a derailment. Indeed, several accidents of derailment linked with cyclic irregularities have been reported, e.g. in the UK and Germany.

The use of Short-Time Fourier Transform (STFT) analysis for evaluating the track geometry quality of a 35 km long track on Bdl 354 from Stockholm to Örebro will be investigated. Based on the STFT analysis, information of track irregularities, both in the time domain (track locations) and in the frequency domain (wavelength content) are obtained. Thus, cyclic irregularities can be clearly identified. As shown in the figure, we observe that, while the results from 2017-05-11 show randomly distributed wavelength content, those from 2017-08-30 are dominated by a fixed wavelength of 13 m at locations around km 17+500, 18+700 and 19+400.

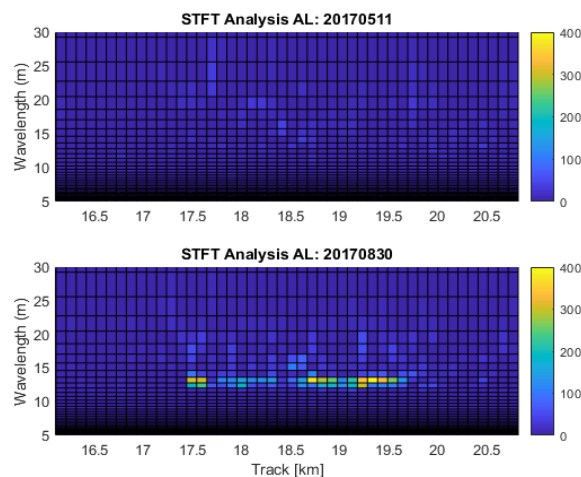

Figure 1. STFT analysis results for alignment D1 of the left rail on km 16-21.

This work is part of the collaboration project, “A systematic approach to improve passenger ride comfort”, between the infrastructure manager Trafikverket and operator SJ AB, together with external partners, aiming to improve the handling of bad ride comfort. The project is also part of the In2Track2 initiative in the EU Innovation Program 3.

Evaluating turnouts using post-positioned measuring car data inclusive the rail surface signal

M.Loidolt¹

¹ Institute of Railway Engineering and Transport Economy, Graz University of Technology, Graz, Austria.
markus.loidolt@tugraz.at

Introduction

Turnouts are indispensable, cost-intensive, safety-relevant and frequently present; therefore, the condition assessment and condition prognosis should be advanced. For reliable forecasts, a data-based evaluation must be applied, whereby new measuring systems and sensor concepts can be developed or existing data can be used. New data sources are primarily useful when questions cannot be answered with existing data, but require a comparatively high implementation effort. In addition, the requirements for databases increase strongly with additional data sources. For this reason, we pursue the approach of extracting condition parameters from existing data of the measuring car.

Methodology, analysis and results

For the evaluation of turnouts, the data of the measuring car must be post-positioned in the first step, otherwise no component-specific conclusions can be made. We use an algorithm developed by Fellingner (accuracy $\pm 25\text{cm}$) as a basis and adapted it for the so-called rail surface signal (accuracy $\pm 2.5\text{ cm}$). This makes it possible to evaluate quality parameters with high resolution and to observe a change over time. With the aid of the rail surface signal, an attempt is made to evaluate the condition of metal parts and to include them in the overall health assessment of turnouts. The following figure is an example of a joint assessment and shows, how a worn insulated rail joint causes a single failure of track geometry to develop and deteriorate. The presented approach allows for a holistic assessment of turnout condition when planning maintenance actions.

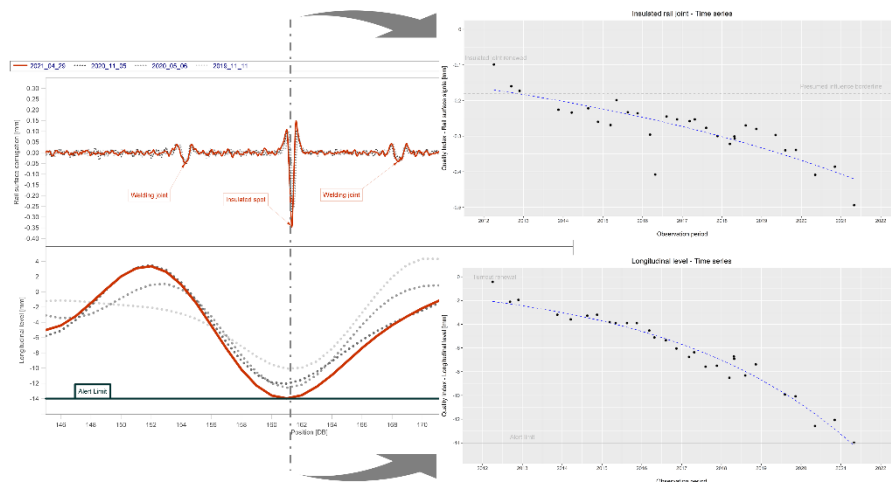

Figure 10. Development of Track Quality for different Tamping Regimes.

References

Fellinger, M.; Neuhold, J.; Marschnig, S. Ballast Condition Monitoring for Turnouts Using Power Spectral Density. J. Transp. Eng. A 2020, 146, 04020099.

Systematic Mapping Review on Railway Track Condition Monitoring 2016-2021

Frida Carlvik, Albert Lau² and Gunnstein T. Frøseth³

¹ Civil and Environmental Engineering, NTNU, Trondheim, Norway. frida.carlvik@ntnu.no

² Civil and Environmental Engineering, NTNU, Trondheim, Norway. Albert.lau@ntnu.no

³ Structural Engineering, NTNU, Trondheim, Norway. gunnstein.t.frøseth@ntnu.no

Introduction

Condition-based maintenance of railway track ensures an increase in safety, infrastructure lifetime, and economy. For condition-based maintenance, the track must be monitored, either by track-following systems or with sensors placed at discrete locations along the track.

Prior to this systematic mapping, there have been several literature reviews related to track condition monitoring. A comprehensive review of the common sensors is given by Farkas in 2019 [1]. Weston et. al reviews instrumented in-service vehicles in 2015 [2]. A systematic literature review of data-driven models for track maintenance prediction was performed in 2020, by Xie et.al [3]. This systematic mapping of the research area provides an overview of the current sensor technology, advances in the field and future research within railway track condition monitoring.

Analysis

The systematic mapping method is inspired by guidelines presented by Petersen, Vakkalanka and Kuzniarz [4]. The systematic mapping method is a repeatable method, which uses keyword extraction for data analysis, such that a larger scope of papers can be analysed compared to traditional literature review methods.

A search was performed in five popular science and engineering databases using the search query “**railway track**” **AND (condition OR status OR quality OR health) AND (monitoring OR detection OR measurements)**. The 725 resulting papers were screened using inclusion criteria, resulting in 159 articles and 6 literature reviews for the systematic mapping. The inclusion criteria were papers specifically on the monitoring of railway track superstructure using measurements, that were published between 2016-2021. The analysis was performed using reference manager EndNote 20, and the text analytics toolbox in MATLAB.

The most popular sensors were acceleration- and vision-based measurements. Vehicle-based measurements are most popular, with other track-following methods and trackside monitoring being less common. Within the vehicle, both axle-box and car-body positioning of sensors is equally popular, and there is no clear preference between in-service vehicles and specific track monitoring vehicles.

Conclusions

The systematic mapping illustrates trends within literature during the years 2016-2021. Although there are clear trends in the choice of sensor, the positioning of the sensor and vehicle choice varies. This indicates that the position of the sensor depends on the purpose of the measurement, for example short-wavelength irregularities being more easily detected through axle-box measurements [1].

References

[1] Weston, P., Roberts, C., Yeo, G., & Stewart, E. (2015). Perspectives on railway track geometry condition monitoring from in-service railway vehicles. *Vehicle System Dynamics*, 53(7), 1063–1091.

<https://doi.org/10.1080/00423114.2015.1034730>

- [2] Farkas, A. (2019). Measurement of Railway Track Geometry: A State-of-the-Art Review. *Periodica Polytechnica Transportation Engineering*, 48(1), 76–88. <https://doi.org/10.3311/PPtr.14145>
- [3] Xie, J., Huang, J., Zeng, C., Jiang, S.-H., & Podlich, N. (2020). Systematic Literature Review on Data-Driven Models for Predictive Maintenance of Railway Track: Implications in Geotechnical Engineering. *Geosciences*, 10(11), 425. <https://doi.org/10.3390/geosciences10110425>
- [4] Petersen, K., Vakkalanka, S., & Kuzniarz, L. (2015). Guidelines for conducting systematic mapping studies in software engineering: An update. *Information and Software Technology*, 64, 1–18. <https://doi.org/10.1016/j.infsof.2015.03.007>

Cyber Resilient approach for Railways

Ravdeep Kour¹, Amit Patwardhan¹ and Ramin Karim¹

¹ Division of Operation and Maintenance Engineering, Luleå University of Technology, Sweden. ravdeep.kour@ltu.se; amit.patwardhan@ltu.se; ramin.karim@ltu.se

Introduction

Digitalisation and Artificial Intelligence (AI) are changing the railway industry. This change exposes the digitalised railway infrastructure to cyber threats. Therefore, cyber resilience becomes an important part of digitalisation of the railways. Cyber resilience consists of different phases of cyber operations as a function of system performance over time during a cyber-attack incident (Wei, 2010 and Haque, 2021). Hence, the purpose of this research is to develop and provide a conceptual model to improve the cyber resilience of railway system from cyber-attacks. This can be realised by developing a cyber resilient approach that can learn the behaviour of the system to predict and detect cyber-attacks and recover quickly from adversities using security controls like self-learning and self-healing capabilities implemented through AI and Machine Learning (ML) techniques (Figure 1).

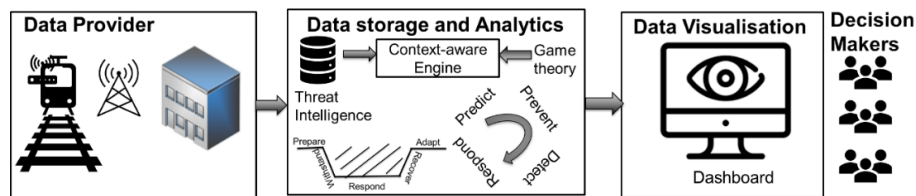

Figure 11. Conceptual model for improving cyber resilience.

Analysis

The cyber resilient approach will help in developing threat models based on its sources (internal and external), actors involved (human, technological, and natural disaster), their actions, goals, and impacts. In addition, these models will help in finding critical areas within the digital infrastructure to improve their cyber resilience by self-learning and adjusting security controls automatically.

Conclusions

It can be concluded that the proposed conceptual model can be used to enhance the railway's cyber resilience maturity and in turn improve the reliability, availability, and safety of the railway system by using AI, ML, cloud computing, and big data technologies.

References

- Haque, M. A., Shetty, S., Gold, K., & Krishnappa, B., "Realizing cyber-physical systems resilience frameworks and security practices", security in cyber-physical systems, Springer, Cham, pp. 1-37, 2021
- Wei, D., & Ji, K., "Resilient industrial control system (RICS): Concepts, formulation, metrics, and insights", 2010 3rd international symposium on resilient control systems, pp. 15-22, 2010.

Railway catenary digital twin: structure, representation and analytics

Amit Patwardhan¹, Adithya Thaduri² and Ramin Karim³

Division of Operation, Maintenance and Acoustics
Luleå University of Technology, Luleå, Sweden

¹ amit.patwardhan@ltu.se

² adithya.thaduri@ltu.se

³ ramin.karim@ltu.se

Introduction

Railway catenary is a critical linear asset required for powering the rail network. It continually requires inspection for its maintenance due to effects like use, weather and vegetation. Sweden currently has about 15000 km of linear assets. Inspection, planning, and maintenance effort for these can be reduced by automation of data collection and analysis process.

Digital twin is a replica of the cyber-physical assets and retain a two-way communication channel online and in real-time. This channel is used to continuously update the behaviour, characteristics, and configuration of the digital twin with the “experiences” of the cyber-physical asset, to support the decision-making process in industrial contexts.

The objective of this ongoing work is to develop and provide a digital twin of the catenary system representing physical attributes, effects of weather and monitoring of vegetation in and around railway corridor. The data collection process is carried out by terrestrial LiDAR scanning mounted on locomotive.

Analysis

LiDAR scanning results into large amount of data in the form of 3D point cloud. This data is processed in a sequence of stages such as filtering, cropping, clustering, segmentation, and classification. These stages of processing result into segmented catenary assets like masts, portals, cantilevers, and individually labelled wires (carrier, contact, tension, reinforcement).

Individual assets information is stored in a relational database for model creation, masts are stored as absolute position and bounding box information. Portals are stored with bounding box information and parent mast pair information. Labelled wires with parent mast pair and mathematically such as the catenary equation $y = a \cdot \cosh(x/a)$. Additionally, asset metadata, state information, event data, entity models, domain knowledge and analytics results become a part of the digital twin.

Conclusions

It can be concluded that such point cloud representation allows efficient storage of information about the catenary assets. As more scans are performed over a period of time, new information is appended to the database. Data extraction can be performed based on region of interest, time, or asset of interest. This transforms the analysis process from a computation heavy problem to efficient data query.

Railway Digitalization – Finnish Frontier

Heikki Kaaranen and Heidi Sunnari

¹ Proxion Ltd, Finland. heikki.kaaranen@proxio.fi, heidi.sunnari@proxion.fi

Currently, railway traffic future development is on focus especially in Europe area. Main topic in this development is to modernize European Train Control System (ETCS) to cover future needs in terms of capacity and reliability.

Nowadays ETCS utilizes GSM-R for radio connections. The Future Railway Mobile Communication System (FRMCS) will use modern radio technology for its radio connections. Just right now it is recognized that this technology is 5G. As time goes by the technology will change. The main issue here is and will be, that ETCS signalling is technology-independent; it is just transported over modern radio path offering adequate reliability and capacity.

When radio connections are used in ETCS traffic between the train and traffic control center, some new aspects will occur which have not been taken into account so far. As a basis for pre-planning and planning procedures as well as everyday maintenance, the radio signal availability and quality must be ensured.

These new radio related procedures must be performed against security requirements set for railways but however with cost efficient and flexible manners. Proxion, as a first company in Finland, has established a moving 5G Lab to be used in railway environment. 5G Lab produces accurate measurements of radio environments and is able to simulate ETCS traffic on message level for connection verification purposes. 5G Lab measurement system contains also reporting platform through which the collected measurement data can be analysed with positioning information thus producing exact picture how radio connections are performing on railway environment.

Finnish frontier: Finland is a bit of exception in case of FRMCS development. Finland does not have to develop migration procedure from GSM-R to 5G, since GSM-R is not used in Finland. As it was mentioned earlier, ETCS signaling traffic is carried within TCP/IP traffic and this traffic can be transferred over any suitable transport, Finland considers also alternative to carry ETCS traffic over 4G and with public networks. As 5G network coverage expands, Finland is going to use public 5G connections for the same purpose. The question here is: are public mobile networks good and reliable enough to carry ETCS critical data traffic?

Currently in 2022 (results may be already available when the seminar takes place in June), Fintraffic organized Digirail project have been measuring Finnish public mobile networks and their behavior over 6000 km track kilometers. These measurements are done with Proxion 5G Laboratory measurement systems.

Universal Cost Model: railway system interdependencies in LCC analyses

C. Casanueva^{1*}, R. Giossi¹, B. de Leeuw¹, I. Kaiser², J. Vinolas², and S. Stichel¹

¹ Department of Engineering Mechanics, KTH, Stockholm, Sweden. *carlosc@kth.se

² School of Engineering, Nebrija University, Madrid, Spain.

Innovations in running gear design do not easily find their way into the market, because they tend to increase the initial cost of the running gear, even if they reduce the system Life Cycle Costs (LCC). The long-term cost reduction also benefits different stakeholders of the railway system, while the initial cost must be paid by the vehicle operator alone. The Universal Cost Model (UCM) developed in EU projects Roll2Rail [1] and NEXTGEAR [2] is a tool being developed for this purpose.

This work will present the UCM and showcase its capabilities for studying the influence of introducing substantial innovations in the running gear, such as single-wheelset bogie metro vehicle concept developed in NEXTGEAR WP2, which investigates the feasibility of using single wheelset bogies with active suspensions for urban trains. The vehicle foresees a single suspension system where the wheelsets are connected through a U-shaped composite material frame to the carbody. The poor ride comfort due to the single suspension step and the poor steering capability due to an 8 m wheelbase are solved by means of dynamic control respectively steering control. A comparison analysis between this innovative case and a classic metro vehicle using the UCM framework will be presented.

As a second example of use for decision making purposes, it is nowadays mandatory to substitute block brakes manufactured in cast iron by novel composite and sintered block brakes, in order to greatly reduce the rolling contact noise. These materials generate a smoother wheel surface, reducing the rolling noise but generating wheel tread wear instead. This hollow wear will create increasing maintenance costs for the operator, but also generate a suboptimal equivalent conicity that will increase track maintenance costs for the infrastructure managers. Additionally, these brakes have poor safety performance in Nordic conditions [3]. The case study uses the Iron Ore line wagons in northern Sweden, where novel block brakes were introduced around year 2010, highlighting different issues in Nordic conditions.

Finally, an analysis of how the UCM can be used for studying different reprofiling strategies is demonstrated, by calculating the estimated material loss and related costs coming from different schedules and strategies addressing both the limit flange thickness before reprofiling, and the thickness of the flange after reprofiling.

References

- [1] J. Melendez, “Roll2Rail D4.3: Cost model methodology,” EU Project Deliverable R2R-T4.3-D-CEI-049–06, Apr. 2017.
- [2] “NEXT generation methods, concepts and solutions for the design of robust and sustainable running GEAR.” <https://cordis.europa.eu/project/id/881803>.
- [3] U. Olofsson, J. Sundh, U. Bik, and R. Nilsson, “The influence of snow on the tread braking performance of a train: A pin-on-disc simulation performed in a climate chamber,” *Journal of Rail and Rapid Transit*, vol. 230, no. 6, pp. 1521–1530, Aug. 2016.

Use of reserved capacity for basic maintenance in Sweden

Daria Ivina^{1,2}, Carl-William Palmqvist^{1,2}

¹ Department of Technology & Society, Lund University, Lund, Sweden

² K2 Swedish Knowledge Centre for Public Transport, Lund, Sweden
daria.ivina@tft.lth.se, carl-william.palmqvist@tft.lth.se

Introduction

With an annual growth of railway traffic, it becomes vital to ensure reliable railway services. To prevent infrastructure failures and guarantee smooth train operation, the infrastructure manager has to provide room for basic maintenance of railway infrastructure components. To secure a sufficient amount of time on track for maintenance, the Swedish Transport Administration has implemented maintenance windows as part of the capacity planning regime (Trafikverket, 2015). In the annually published network statement, there are windows ranging from two to six hours that have already been booked for maintenance activities. During the annual timetabling process, these time slots are already known, and train traffic is planned around them. Maintenance contractors are responsible for planning and scheduling maintenance, as well as reserving time on track inside the maintenance windows for performing basic maintenance.

This study purpose is to investigate the use of reserved capacity by the contractor to perform trackwork in Sweden. We aim to reveal how much of the reserved capacity in maintenance windows are used by the contractor and what basic maintenance volume is performed inside and outside of given maintenance windows.

Analysis

We analysed three datasets, planned and recorded trackwork and maintenance windows records in the south of Sweden, 2019 and 2020, obtained from the Swedish Transport Administration. The study area is a railway line in southern Sweden between Arlöv and Nässjö Central, a double-track area with high-intensity traffic. The data processing method was used to identify the trackwork performed inside and outside of given maintenance windows.

Conclusions

The results showed that 24 % of given maintenance windows in 2019 and 2020 were booked and used for basic maintenance. However, out of the booked time for basic maintenance inside 24% of maintenance windows, 51 % of the time on track was used for maintenance. Moreover, only 11% of the total volume of basic maintenance in 2019 and 2020 was performed inside the maintenance windows. These results emphasise the importance of improving the planning for maintenance windows with respect to their actual use.

References

Trafikverket, 2015. Banarbetstider för underhåll av järnvägsanläggningen. TDOK2015:0484. u.o.: Trafikverket.

Digitalizing supervision activities and documentation

François Got¹, Kevin Lane² and Niko Klasila³

¹ Railway consulting department, Welado, Helsinki, Uusimaa. francois.got@welado.fi

² Railway consulting department, Welado, Oulu, Pohjois-Pohjanmaa. kevin.lane@welado.fi

³ Railway consulting department, Welado, Oulu, Pohjois-Pohjanmaa. niko.klasila@welado.fi

Introduction

Railway maintenance oversight comes with the challenges of documenting maintenance supervision activities and analysing observations made by the supervisors. To this end we looked for solutions with a low barrier to entry, for example avoiding purchase of expensive software or licenses.

Analysis

Using the supervision application, it is possible to document all supervision activities and also produce a report in a timely manner that can be submitted to the Railway Administrator and to the various maintenance contractors. The supervision application requires PowerApps, Power Automate, OneDrive for Business and Excel Online. When paired with a visualisation software such as Power BI, it is easy to visualize the results. Power BI has also been used to visualize the inspection results and maintenance activities performed by the maintenance contractors. It is possible to visualize the data, and for example, to point out locations missing inspection reports. It is hoped that Power BI can be used to develop the report views for the Railway Administrator's data reporting system.

Conclusions

These tools are available within the Office 365 environment. There are more sophisticated options available on the market, but these tools are readily available at low cost. It takes some IT skills and knowledge of the intended use. They can be modified depending on the need and are applicable to many fields. Imagination is the limit.

Developing An Energy Labelling System for Rail Vehicles: A Survey of European Railway Stakeholders

Zhendong Liu¹, Mats Berg¹ and Tohmmmy Bustad²

¹ KTH Royal Institute of Technology, Stockholm, Sweden. zhendong@kth.se & mabe@kth.se

² Trafikverket, Borlänge, Sweden. tohmmmy.bustad@trafikverket.se

Abstract

To achieve the goals of energy saving and reduced CO₂ emissions, energy labelling systems, which are marked with an instruction list to show a product's energy usage or efficiency level, are initiated in most countries and cover a wide range of products. It is effective in reflecting the energy efficiencies of products and encourages technology innovations. Although rail transportation is an energy-efficient transport mode, there is no such effort made up to now. In order to attract passengers and end-users to use rail transport and support the development of energy-efficient rail vehicles, an energy labelling system for rail vehicles has been proposed. Although the development of such a system is necessary, different railway stakeholders may have different views and expectations on the system, so a questionnaire survey is carried out to collect the stakeholders' opinions. In the survey, 19 European railway stakeholders from seven countries, including train manufacturers, train operators, transport authorities, infrastructure managers etc., are involved, as shown in Figure 1. Most of the railway stakeholders show their willingness to establish the energy labelling system for rail vehicles. The survey helps us identify the needs of different railway stakeholders, working direction for the next step and general guidelines during development. Although it would take some time to develop a proper energy labelling system, establishing such a system within the rail sector will have a significant and profound influence, which can promote rail transport into a more energy-efficient and lower CO₂-emission transport mode for the future.

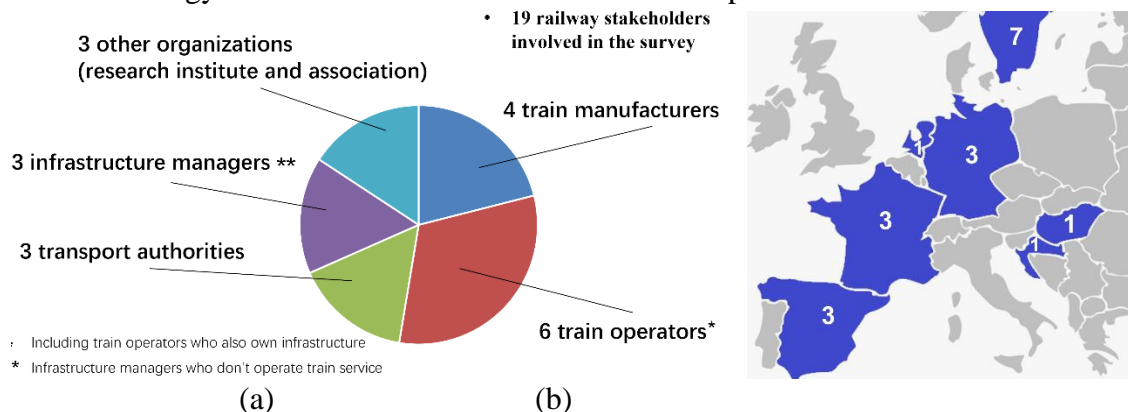

Figure 1. Composition (a) and locations (b) of 19 European railway stakeholders involved.

References

FINE2 Webpage: https://projects.shift2rail.org/s2r_ipcc_n.aspx?p=fine-2

Zhendong Liu, Mats Berg and Tohmmmy Bustad, Review of the existing energy labelling systems and a proposal for rail vehicles, *Journal of Rail and Rapid Transit*, 235(4), p518-528, 2021.

<https://journals.sagepub.com/doi/full/10.1177/0954409720926362>